

Affordable automation that increases production and improves quality.



# Bug-O Sub-Arc Tractor

## Heavy Duty for Welding Fillet and Butt Joints.



The Bug-O System's Submerged-Arc Tractor is outfitted with all of the necessary equipment for performing submerged-arc welding for fillet and butt joints. The integrated wire-feeder and torch provide racking for cross-seam and vertical position fine-tuning. The heavy duty tractor is capable of travel speeds ranging from 5-100 ipm (127-2540 mm/min). It can carry a maximum payload of 350 lb (159 kg). All of the tractor controls are integrated into the wire-feed control unit, providing a seamless interface to the complete welding process. Heavy duty wire feed equipment is included on the machine with wire feed speed capabilities of 25 to 600 inches per minute for wire diameters of 1/16" - 7/32" (1.59 - 5.56 mm). An optional flux recovery unit provides recycling of the submerged-arc flux.



**BUG-O SYSTEMS**  
A DIVISION OF WELD TOOLING CORPORATION



Консультации и поставка сварочного оборудования ООО "ВЭЛДТЭК"  
Телефон: (495) 981-0020 Интернет: <http://www.lincolnweld.ru> E-mail: [le@weldtech.ru](mailto:le@weldtech.ru)



# Bug-o Sub-Arc Tractor

## Controls:

### HDT-1086 Control Box

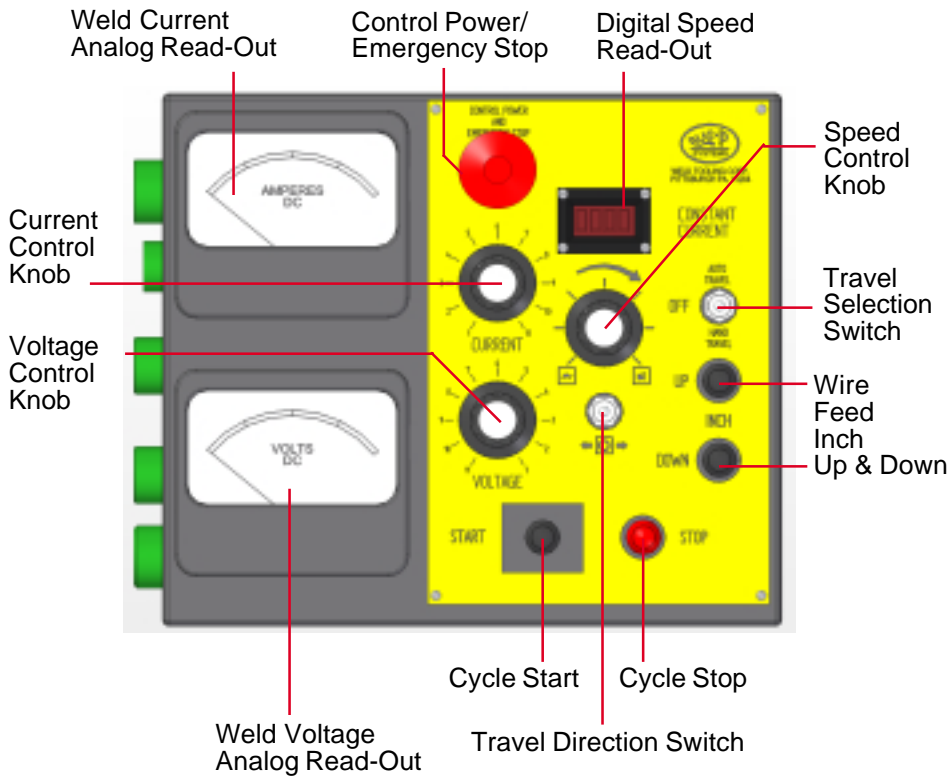

## Dimensions:

### HDT-1300

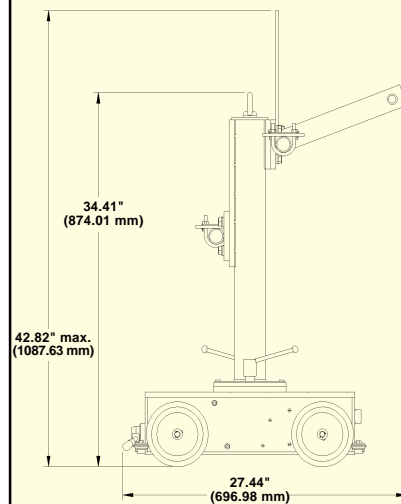

### HDT-1000

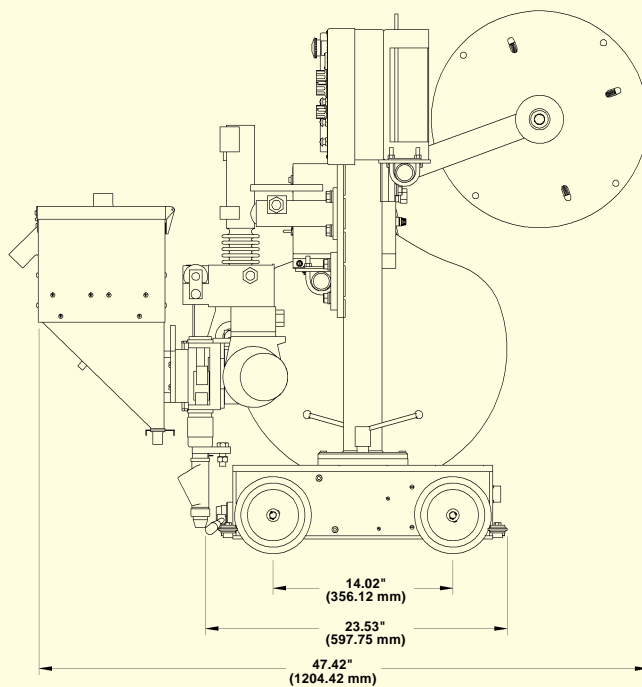
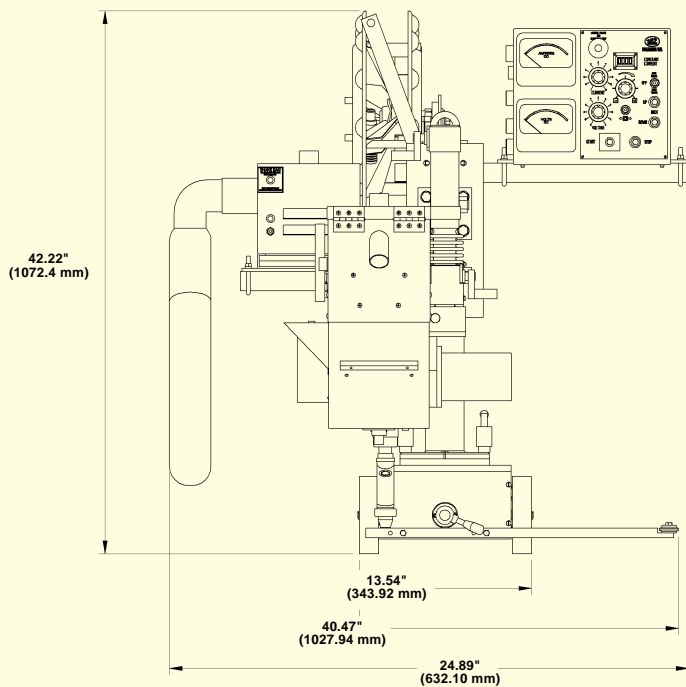

Net Weight: 255 lbs. (116 kg)