

PIPELINER 200D

For use with machines having Code Numbers 10929

Safety Depends on You

Lincoln arc welding and cutting equipment is designed and built with safety in mind. However, your overall safety can be increased by proper installation ... and thoughtful operation on your part. **DO NOT INSTALL, OPERATE OR REPAIR THIS EQUIPMENT WITHOUT READING THIS MANUAL AND THE SAFETY PRECAUTIONS CONTAINED THROUGHOUT.** And, most importantly, think before you act and be careful.

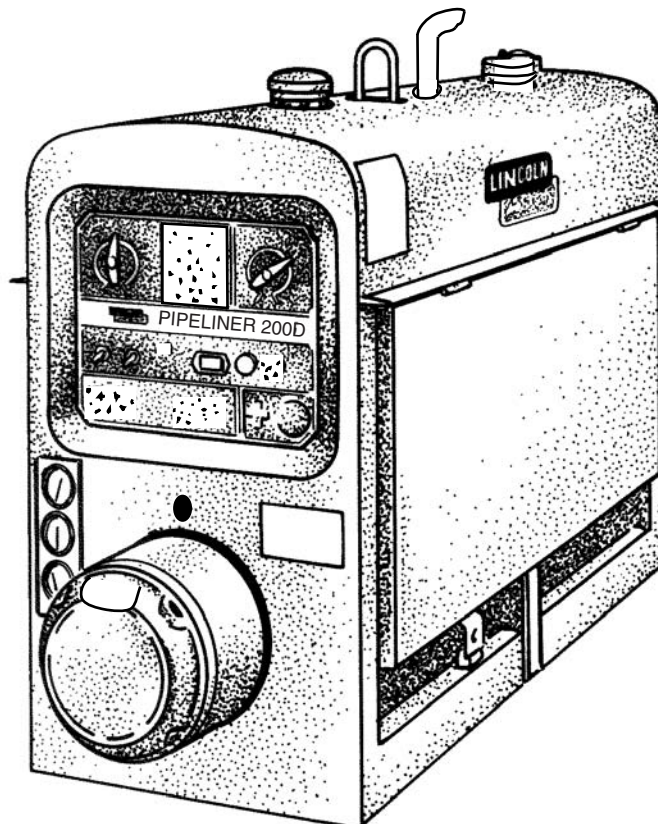

OPERATOR'S MANUAL

LINCOLN[®]
ELECTRIC

Copyright © 2004 Lincoln Global Inc.

• World's Leader in Welding and Cutting Products •

• Sales and Service through Subsidiaries and Distributors Worldwide •

Cleveland, Ohio 44117-1199 U.S.A. TEL: 216.481.8100 FAX: 216.486.1751 WEB SITE: www.lincolnelectric.com

⚠ WARNING

⚠ CALIFORNIA PROPOSITION 65 WARNINGS ⚠

Diesel engine exhaust and some of its constituents are known to the State of California to cause cancer, birth defects, and other reproductive harm.

The Above For Diesel Engines

The engine exhaust from this product contains chemicals known to the State of California to cause cancer, birth defects, or other reproductive harm.

The Above For Gasoline Engines

ARC WELDING CAN BE HAZARDOUS. PROTECT YOURSELF AND OTHERS FROM POSSIBLE SERIOUS INJURY OR DEATH. KEEP CHILDREN AWAY. PACEMAKER WEARERS SHOULD CONSULT WITH THEIR DOCTOR BEFORE OPERATING.

Read and understand the following safety highlights. For additional safety information, it is strongly recommended that you purchase a copy of "Safety in Welding & Cutting - ANSI Standard Z49.1" from the American Welding Society, P.O. Box 351040, Miami, Florida 33135 or CSA Standard W117.2-1974. A Free copy of "Arc Welding Safety" booklet E205 is available from the Lincoln Electric Company, 22801 St. Clair Avenue, Cleveland, Ohio 44117-1199.

BE SURE THAT ALL INSTALLATION, OPERATION, MAINTENANCE AND REPAIR PROCEDURES ARE PERFORMED ONLY BY QUALIFIED INDIVIDUALS.



FOR ENGINE powered equipment.

1.a. Turn the engine off before troubleshooting and maintenance work unless the maintenance work requires it to be running.



1.b. Operate engines in open, well-ventilated areas or vent the engine exhaust fumes outdoors.



1.c. Do not add the fuel near an open flame welding arc or when the engine is running. Stop the engine and allow it to cool before refueling to prevent spilled fuel from vaporizing on contact with hot engine parts and igniting. Do not spill fuel when filling tank. If fuel is spilled, wipe it up and do not start engine until fumes have been eliminated.

1.d. Keep all equipment safety guards, covers and devices in position and in good repair. Keep hands, hair, clothing and tools away from V-belts, gears, fans and all other moving parts when starting, operating or repairing equipment.

1.e. In some cases it may be necessary to remove safety guards to perform required maintenance. Remove guards only when necessary and replace them when the maintenance requiring their removal is complete. Always use the greatest care when working near moving parts.



1.f. Do not put your hands near the engine fan. Do not attempt to override the governor or idler by pushing on the throttle control rods while the engine is running.

1.g. To prevent accidentally starting gasoline engines while turning the engine or welding generator during maintenance work, disconnect the spark plug wires, distributor cap or magneto wire as appropriate.



1.h. To avoid scalding, do not remove the radiator pressure cap when the engine is hot.



ELECTRIC AND MAGNETIC FIELDS may be dangerous

2.a. Electric current flowing through any conductor causes localized Electric and Magnetic Fields (EMF). Welding current creates EMF fields around welding cables and welding machines

2.b. EMF fields may interfere with some pacemakers, and welders having a pacemaker should consult their physician before welding.

2.c. Exposure to EMF fields in welding may have other health effects which are now not known.

2.d. All welders should use the following procedures in order to minimize exposure to EMF fields from the welding circuit:

2.d.1. Route the electrode and work cables together - Secure them with tape when possible.

2.d.2. Never coil the electrode lead around your body.

2.d.3. Do not place your body between the electrode and work cables. If the electrode cable is on your right side, the work cable should also be on your right side.

2.d.4. Connect the work cable to the workpiece as close as possible to the area being welded.

2.d.5. Do not work next to welding power source.

Mar '95

PIPELINER 200G





ELECTRIC SHOCK can kill.

- 3.a. The electrode and work (or ground) circuits are electrically "hot" when the welder is on. Do not touch these "hot" parts with your bare skin or wet clothing. Wear dry, hole-free gloves to insulate hands.
- 3.b. Insulate yourself from work and ground using dry insulation. Make certain the insulation is large enough to cover your full area of physical contact with work and ground.
- In addition to the normal safety precautions, if welding must be performed under electrically hazardous conditions (in damp locations or while wearing wet clothing; on metal structures such as floors, gratings or scaffolds; when in cramped positions such as sitting, kneeling or lying, if there is a high risk of unavoidable or accidental contact with the workpiece or ground) use the following equipment:**
- Semiautomatic DC Constant Voltage (Wire) Welder.
 - DC Manual (Stick) Welder.
 - AC Welder with Reduced Voltage Control.
- 3.c. In semiautomatic or automatic wire welding, the electrode, electrode reel, welding head, nozzle or semiautomatic welding gun are also electrically "hot".
- 3.d. Always be sure the work cable makes a good electrical connection with the metal being welded. The connection should be as close as possible to the area being welded.
- 3.e. Ground the work or metal to be welded to a good electrical (earth) ground.
- 3.f. Maintain the electrode holder, work clamp, welding cable and welding machine in good, safe operating condition. Replace damaged insulation.
- 3.g. Never dip the electrode in water for cooling.
- 3.h. Never simultaneously touch electrically "hot" parts of electrode holders connected to two welders because voltage between the two can be the total of the open circuit voltage of both welders.
- 3.i. When working above floor level, use a safety belt to protect yourself from a fall should you get a shock.
- 3.j. Also see Items 6.c. and 8.



ARC RAYS can burn.

- 4.a. Use a shield with the proper filter and cover plates to protect your eyes from sparks and the rays of the arc when welding or observing open arc welding. Headshield and filter lens should conform to ANSI Z87.1 standards.
- 4.b. Use suitable clothing made from durable flame-resistant material to protect your skin and that of your helpers from the arc rays.
- 4.c. Protect other nearby personnel with suitable, non-flammable screening and/or warn them not to watch the arc nor expose themselves to the arc rays or to hot spatter or metal.



FUMES AND GASES can be dangerous.

- 5.a. Welding may produce fumes and gases hazardous to health. Avoid breathing these fumes and gases. When welding, keep your head out of the fume. Use enough ventilation and/or exhaust at the arc to keep fumes and gases away from the breathing zone. **When welding with electrodes which require special ventilation such as stainless or hard facing (see instructions on container or MSDS) or on lead or cadmium plated steel and other metals or coatings which produce highly toxic fumes, keep exposure as low as possible and below Threshold Limit Values (TLV) using local exhaust or mechanical ventilation. In confined spaces or in some circumstances, outdoors, a respirator may be required. Additional precautions are also required when welding on galvanized steel.**
- 5.b. Do not weld in locations near chlorinated hydrocarbon vapors coming from degreasing, cleaning or spraying operations. The heat and rays of the arc can react with solvent vapors to form phosgene, a highly toxic gas, and other irritating products.
- 5.c. Shielding gases used for arc welding can displace air and cause injury or death. Always use enough ventilation, especially in confined areas, to insure breathing air is safe.
- 5.d. Read and understand the manufacturer's instructions for this equipment and the consumables to be used, including the material safety data sheet (MSDS) and follow your employer's safety practices. MSDS forms are available from your welding distributor or from the manufacturer.
- 5.e. Also see item 1.b.

Mar '95

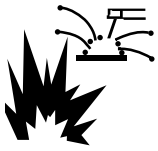

WELDING SPARKS can cause fire or explosion.

6.a. Remove fire hazards from the welding area. If this is not possible, cover them to prevent the welding sparks from starting a fire.

Remember that welding sparks and hot materials from welding can easily go through small cracks and openings to adjacent areas. Avoid welding near hydraulic lines. Have a fire extinguisher readily available.

- 6.b. Where compressed gases are to be used at the job site, special precautions should be used to prevent hazardous situations. Refer to "Safety in Welding and Cutting" (ANSI Standard Z49.1) and the operating information for the equipment being used.
- 6.c. When not welding, make certain no part of the electrode circuit is touching the work or ground. Accidental contact can cause overheating and create a fire hazard.
- 6.d. Do not heat, cut or weld tanks, drums or containers until the proper steps have been taken to insure that such procedures will not cause flammable or toxic vapors from substances inside. They can cause an explosion even though they have been "cleaned". For information, purchase "Recommended Safe Practices for the Preparation for Welding and Cutting of Containers and Piping That Have Held Hazardous Substances", AWS F4.1 from the American Welding Society (see address above).
- 6.e. Vent hollow castings or containers before heating, cutting or welding. They may explode.
- 6.f. Sparks and spatter are thrown from the welding arc. Wear oil free protective garments such as leather gloves, heavy shirt, cuffless trousers, high shoes and a cap over your hair. Wear ear plugs when welding out of position or in confined places. Always wear safety glasses with side shields when in a welding area.
- 6.g. Connect the work cable to the work as close to the welding area as practical. Work cables connected to the building framework or other locations away from the welding area increase the possibility of the welding current passing through lifting chains, crane cables or other alternate circuits. This can create fire hazards or overheat lifting chains or cables until they fail.
- 6.h. Also see item 1.c.

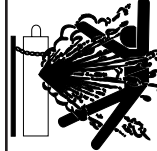

CYLINDER may explode if damaged.

7.a. Use only compressed gas cylinders containing the correct shielding gas for the process used and properly operating regulators designed for the gas and pressure used. All hoses, fittings, etc. should be suitable for the application and maintained in good condition.

- 7.b. Always keep cylinders in an upright position securely chained to an undercarriage or fixed support.
- 7.c. Cylinders should be located:
 - Away from areas where they may be struck or subjected to physical damage.
 - A safe distance from arc welding or cutting operations and any other source of heat, sparks, or flame.
- 7.d. Never allow the electrode, electrode holder or any other electrically "hot" parts to touch a cylinder.
- 7.e. Keep your head and face away from the cylinder valve outlet when opening the cylinder valve.
- 7.f. Valve protection caps should always be in place and hand tight except when the cylinder is in use or connected for use.
- 7.g. Read and follow the instructions on compressed gas cylinders, associated equipment, and CGA publication P-1, "Precautions for Safe Handling of Compressed Gases in Cylinders," available from the Compressed Gas Association 1235 Jefferson Davis Highway, Arlington, VA 22202.



FOR ELECTRICALLY powered equipment.

- 8.a. Turn off input power using the disconnect switch at the fuse box before working on the equipment.
- 8.b. Install equipment in accordance with the U.S. National Electrical Code, all local codes and the manufacturer's recommendations.
- 8.c. Ground the equipment in accordance with the U.S. National Electrical Code and the manufacturer's recommendations.

Mar '95

PRÉCAUTIONS DE SÛRETÉ

Pour votre propre protection lire et observer toutes les instructions et les précautions de sûreté spécifiques qui paraissent dans ce manuel aussi bien que les précautions de sûreté générales suivantes:

Sûreté Pour Soudage A L'Arc

1. Protégez-vous contre la secousse électrique:
 - a. Les circuits à l'électrode et à la pièce sont sous tension quand la machine à souder est en marche. Eviter toujours tout contact entre les parties sous tension et la peau nue ou les vêtements mouillés. Porter des gants secs et sans trous pour isoler les mains.
 - b. Faire très attention de bien s'isoler de la masse quand on soude dans des endroits humides, ou sur un plancher métallique ou des grilles métalliques, principalement dans les positions assis ou couché pour lesquelles une grande partie du corps peut être en contact avec la masse.
 - c. Maintenir le porte-électrode, la pince de masse, le câble de soudage et la machine à souder en bon et sûr état de fonctionnement.
 - d. Ne jamais plonger le porte-électrode dans l'eau pour le refroidir.
 - e. Ne jamais toucher simultanément les parties sous tension des porte-électrodes connectés à deux machines à souder parce que la tension entre les deux pinces peut être le total de la tension à vide des deux machines.
 - f. Si on utilise la machine à souder comme une source de courant pour soudage semi-automatique, ces précautions pour le porte-électrode s'appliquent aussi au pistolet de soudage.
2. Dans le cas de travail au dessus du niveau du sol, se protéger contre les chutes dans le cas où on recoit un choc. Ne jamais enrouler le câble-électrode autour de n'importe quelle partie du corps.
3. Un coup d'arc peut être plus sévère qu'un coup de soleil, donc:
 - a. Utiliser un bon masque avec un verre filtrant approprié ainsi qu'un verre blanc afin de se protéger les yeux du rayonnement de l'arc et des projections quand on soude ou quand on regarde l'arc.
 - b. Porter des vêtements convenables afin de protéger la peau de soudeur et des aides contre le rayonnement de l'arc.
 - c. Protéger l'autre personnel travaillant à proximité au soudage à l'aide d'écrans appropriés et non-inflammables.
4. Des gouttes de laitier en fusion sont émises de l'arc de soudage. Se protéger avec des vêtements de protection libres de l'huile, tels que les gants en cuir, chemise épaisse, pantalons sans revers, et chaussures montantes.
5. Toujours porter des lunettes de sécurité dans la zone de soudage. Utiliser des lunettes avec écrans latéraux dans les

zones où l'on pique le laitier.

6. Eloigner les matériaux inflammables ou les recouvrir afin de prévenir tout risque d'incendie dû aux étincelles.
7. Quand on ne soude pas, poser la pince à un endroit isolé de la masse. Un court-circuit accidentel peut provoquer un échauffement et un risque d'incendie.
8. S'assurer que la masse est connectée le plus près possible de la zone de travail qu'il est pratique de le faire. Si on place la masse sur la charpente de la construction ou d'autres endroits éloignés de la zone de travail, on augmente le risque de voir passer le courant de soudage par les chaînes de levage, câbles de grue, ou autres circuits. Cela peut provoquer des risques d'incendie ou d'échauffement des chaînes et des câbles jusqu'à ce qu'ils se rompent.
9. Assurer une ventilation suffisante dans la zone de soudage. Ceci est particulièrement important pour le soudage de tôles galvanisées plombées, ou cadmiées ou tout autre métal qui produit des fumées toxiques.
10. Ne pas souder en présence de vapeurs de chlore provenant d'opérations de dégraissage, nettoyage ou pistolage. La chaleur ou les rayons de l'arc peuvent réagir avec les vapeurs du solvant pour produire du phosgène (gas fortement toxique) ou autres produits irritants.
11. Pour obtenir de plus amples renseignements sur la sûreté, voir le code "Code for safety in welding and cutting" CSA Standard W 117.2-1974.

PRÉCAUTIONS DE SÛRETÉ POUR LES MACHINES À SOUDER À TRANSFORMATEUR ET À REDRESSEUR

1. Relier à la terre le châssis du poste conformément au code de l'électricité et aux recommandations du fabricant. Le dispositif de montage ou la pièce à souder doit être branché à une bonne mise à la terre.
2. Autant que possible, l'installation et l'entretien du poste seront effectués par un électricien qualifié.
3. Avant de faire des travaux à l'intérieur de poste, la débrancher à l'interrupteur à la boîte de fusibles.
4. Garder tous les couvercles et dispositifs de sûreté à leur place.

Mar. '93

PIPELINER 200G



Thank You

for selecting a **QUALITY** product by Lincoln Electric. We want you to take pride in operating this Lincoln Electric Company product
••• as much pride as we have in bringing this product to you!

Please Examine Carton and Equipment For Damage Immediately

When this equipment is shipped, title passes to the purchaser upon receipt by the carrier. Consequently, Claims for material damaged in shipment must be made by the purchaser against the transportation company at the time the shipment is received.

Please record your equipment identification information below for future reference. This information can be found on your machine nameplate.

Product _____

Model Number _____

Code Number or Date Code _____

Serial Number _____

Date Purchased _____

Where Purchased _____

Whenever you request replacement parts or information on this equipment, always supply the information you have recorded above. The code number is especially important when identifying the correct replacement parts.

On-Line Product Registration

- Register your machine with Lincoln Electric either via fax or over the Internet.

- For faxing: Complete the form on the back of the warranty statement included in the literature packet accompanying this machine and fax the form per the instructions printed on it.
- For On-Line Registration: Go to our **WEB SITE at www.lincolnelectric.com**. Choose "Quick Links" and then "Product Registration". Please complete the form and submit your registration.

Read this Operators Manual completely before attempting to use this equipment. Save this manual and keep it handy for quick reference. Pay particular attention to the safety instructions we have provided for your protection. The level of seriousness to be applied to each is explained below:

⚠ WARNING

This statement appears where the information **must** be followed **exactly** to avoid **serious personal injury** or **loss of life**.

⚠ CAUTION

This statement appears where the information **must** be followed to avoid **minor personal injury** or **damage to this equipment**.

	Page
Installation	Section A
Technical Specifications	A-1
Safety Precautions.....	A-2
Exhaust Spark Arrester.....	A-2
Location / Ventilation.	A-2
Machine Grounding	A-2
Lift Bail.....	A-2
Trailers.....	A-3
Polarity Control and Cable Sizes	A-3
Pre-Operation Service	A-3
Oil.....	A-4
Fuel.....	A-4
Cooling System.....	A-4
Battery Charging.....	A-4
Operation	Section B
Safety Precautions	B-1
General Description	B-1
Design Summary.....	B-1,B-2
Engine Operation.....	B-2
Starting the Perkins 104.22 Engine	B-2
Stopping the Engine	B-2
Typical Fuel Consumption	B-2
Engine Break-In.....	B-3
Welder Operation.....	B-3
Duty Cycle	B-3
Control of Welding Current	B-3
Idle Operation.....	B-4
Auxiliary Power.....	B-4
Accessories	Section C
Optional Equipment (Field Installed)	C-1
Maintenance	Section D
Safety Precautions	D-1
General Instructions	D-1
Cooling System	D-1
Engine Maintenance.....	D-1
Bearings	D-2
Commutator and Brushes.....	D-2
Idle Maintenance	D-2
Nameplates	D-2
Purging Air from Fuel System.....	D-2,D-3
Engine Service Chart.....	D-3
Troubleshooting	Section E
Safety Precautions.....	E-1
How to Use Troubleshooting Guide.....	E-1
Troubleshooting Guide.....	E-2 thru E-7
Diagrams	Section F
Wiring Diagram	F-1
Remote Control Wiring / Connection Diagram(Optional)	F-2
Dimension Print.....	F-3
Parts Manual	P448

TECHNICAL SPECIFICATIONS - Pipeliner 200D (K6090-9)

INPUT - DIESEL ENGINE						
Make/Model	Description	Horsepower	Operating SPEED	Displacement cu. in.(ltrs)	Starting System	Capacities
Perkins 104.22	4 Cylinder 4 Stroke Naturally Aspirated Water Cooled Engine	28.2 HP @ 1600RPM	High 1600RPM Full Load 1550RPM Low Idle 1400RPM	135.6 (2.2)	12VDC Battery and starter Push Button Starter (650 Cold crank amps)	Fuel: 15gal.(57L) Oil: 8.7 qts. (8.2L)
						Radiator Coolant 9.5 qts. (9.0L)
RATED OUTPUT @ 104°F(40C°) - WELDER						
DESCRIPTION		RATED DC OUTPUT VOLTS @ RATED AMPS		DUTY CYCLE*	DC CURRENT RANGE Fine Adjustment in each Range	
200 Amp DC Welder All Copper Windings Pure DC Power Generator		Lincoln Plus Rating 40V @ 200A NEMA Rating 28V @ 200A		60%	40-300 Amps	
RATED OUTPUT @ 104°F(40C°) - GENERATOR						
Auxiliary Power ^{1*}						
1.80 kW, 15 Amps @ 120V DC @ 35% Duty Cycle						
ENGINE COMPONENTS						
LUBRICATION		FUEL SYSTEM			GOVERNOR	
Full Pressure with Full Flow Filter		Indirect Fuel Injector Electrical Shutoff Solenoid Mechanical Fuel Pump			Mechanical Governor	
AIR CLEANER	ENGINE IDLER	MUFFLER			ENGINE PROTECTION	
Single Element	Automatic Idler	Low noise Muffler: Made from long life, aluminized steel.			Shutdown on low oil pressure and engine temperature.	
PHYSICAL DIMENSIONS						
HEIGHT	WIDTH		DEPTH		WEIGHT	
40.94** in. 1039.9 mm	24.00 in. 609.6 mm		66.50in. 1689.1 mm		1318 lbs. (598 kg.)	
**Top of enclosure, add 8.0" (203.2mm) for exhaust						

1. Output rating in watts is equivalent to volt-amperes at unity power factor. Output voltage is within ± 10% at all loads up to rated capacity. When welding, available auxiliary power will be reduced.

* Based on a 10 minute period.

PIPELINER 200D



SAFETY PRECAUTIONS

⚠ WARNING

Do not attempt to use this equipment until you have thoroughly read the engine manufacturer's manual supplied with your welder. It includes important safety precautions, detailed engine starting, operating and maintenance instructions, and parts lists.



ELECTRIC SHOCK can kill.

- Do not touch electrically live parts or electrode with skin or wet clothing.
- Insulate yourself from work and ground
- Always wear dry insulating gloves.



ENGINE EXHAUST can kill.

- Use in open, well ventilated areas or vent exhaust outside.



MOVING PARTS can injure.

- Do not operate with doors open or guards off.
- Stop engine before servicing.
- Keep away from moving parts.

See additional warning information at front of this operator's manual.

EXHAUST SPARK ARRESTER

Some federal, state, or local laws may require that engines be equipped with exhaust spark arresters when they are operated in certain locations where unarrested sparks may present a fire hazard. The standard mufflers included with these welders do not qualify as spark arresters. When required by local regulations, suitable spark arrester must be installed and properly maintained.

⚠ CAUTION

Use of an incorrect arrester may lead to engine damage or performance loss. Contact the engine manufacturer for specific recommendations.

LOCATION / VENTILATION

Always operate the welder with the doors closed. Leaving the doors open changes the designed air flow and may cause overheating.

The welder should be located to provide an unrestricted flow of clean, cool air. Also, locate the welder so that engine exhaust fumes are properly vented to an outside area.

⚠ CAUTION

DO NOT MOUNT OVER COMBUSTIBLE SURFACES.

Where there is a combustible surface directly under stationary or fixed electrical equipment, the surface shall be covered with a steel plate at least .06"(1.6mm) thick, which shall extend not more than 5.90"(150mm) beyond the equipment on all side.

MACHINE GROUNDING

According to the United States National Electrical Code, the frame of this portable generator is not required to be grounded and is permitted to serve as the grounding means for cord connected equipment plugged into its receptacle.

Some state, local, or other codes or unusual operating circumstances may require the machine frame to be grounded. It is recommended that you determine the extent to which such requirements may apply to your particular situation and follow them explicitly. A machine grounding stud marked with the symbol \oplus is provided on the welding generator frame foot. In general, if the machine is to be grounded it should be connected with a #8 or larger copper wire to a solid earth ground such as a metal water pipe going into the ground for at least ten feet and having no insulated joints, or to the metal framework of a building which has been effectively grounded. The U.S. National Electrical Code lists a number of alternate means of grounding electrical equipment.

LIFT BAIL

A lift bail is provided for lifting with a hoist.

⚠ WARNING



FALLING EQUIPMENT can cause injury.

- Lift only with equipment of adequate lifting capacity.
- Be sure machine is stable when lifting.
- Do not lift this machine using lift bale if it is equipped with a heavy accessory such as trailer or gas cylinder.
- Do not lift machine if lift bail is damaged.
- Do not operate machine while suspended from lift bail.

TRAILERS (See ACCESSORIES SECTION)

If the user adapts a non-Lincoln trailer, he must assume responsibility that the method of attachment and usage does not result in a safety hazard, nor damage the welding equipment. Some of the factors to be considered are as follows:

1. Design capacity of trailer vs. weight of Lincoln equipment and likely additional attachments.
2. Proper support of, and attachment to, the base of the welding equipment so there will be no undue stress to the framework.
3. Proper placement of the equipment on the trailer to ensure stability side to side and front to back when being moved and when standing by itself while being operated or serviced.
4. Typical conditions of use, i.e., travel speed; roughness of surface on which the trailer will be operated; environmental conditions; likely maintenance.
5. Conformance with federal, state, and local laws. ⁽¹⁾

⁽¹⁾ Consult applicable federal, state, and local laws regarding specific requirements for use on public highways.

VEHICLE MOUNTING**⚠ WARNING**

Improperly mounted concentrated loads may cause unstable vehicle handling and tires or other components to fail.

- Only transport this Equipment on serviceable vehicles which are rated and designed for such loads.
- Distribute, balance and secure loads so vehicle is stable under conditions of use.
- Do not exceed maximum rated loads for components such as suspension, axles and tires.
- Mount equipment base to metal bed or frame of vehicle.
- Follow vehicle manufacture's instructions.

POLARITY CONTROL AND CABLE SIZES

With the engine off, route the electrode and work cables through the strain relief bracket on the base and connect to the studs located below the fuel tank mounting rail. (see size recommendations below). For **Positive** polarity, connect the electrode cable to the terminal marked "**Positive**". For **Negative** polarity, connect the electrode cable to the "**Negative**" stud. These connections should be checked periodically and tightened if necessary.

When welding at a considerable distance from the welder, be sure you use ample size welding cables.

RECOMMENDED COPPER CABLE SIZES			
		Cable Sizes for Combined Length of Electrode Plus Work Cable	
Amps	Duty Cycle	Up to 200 ft	200-250 ft
200	60%	1	1/0

PRE-OPERATION SERVICE**⚠ CAUTION**

READ the engine operating and maintenance instructions supplied with this machine.

⚠ WARNING

DIESEL FUEL
can
cause fire

- Stop engine while fueling.
 - Do not smoke when fueling.
 - Keep sparks and flame away from tank.
 - Do not leave unattended while fueling.
 - Wipe up spilled fuel and allow fumes to clear before starting engine.
 - Do not overfill tank, fuel expansion may cause overflow.
- DIESEL FUEL ONLY**

OIL

This unit is supplied from the factory with the engine crankcase filled with a high quality SAE 10W/30 oil. This oil should be acceptable for most typical ambient temperatures. Consult the engine operation manual for specific engine manufacturers recommendations. Upon receipt of the welder, check the engine dipstick to be sure the oil is at the "full" mark. Add if required. **DO NOT OVERFILL.**

FUEL

Fill the fuel tank with the grade of fuel recommended in the Engine Operator's Manual. Make sure fuel valve on the sediment bowl and water separator are in the open position.

COOLING SYSTEM

The radiator has been filled at the factory with a 50-50 mixture of ethylene glycol antifreeze and water. Check the radiator level and add a 50-50 solution as needed. (See engine manual or antifreeze container for alternate antifreeze recommendations.)

BATTERY CHARGING
WARNING

GASES FROM BATTERY can explode.
 • Keep sparks, flame and cigarettes away.

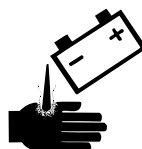

BATTERY ACID can burn eyes and skin.
 • Wear gloves and eye protection and be careful when boosting, charging or working near battery.

To prevent EXPLOSION when:

- Installing a new battery - disconnect the negative cable from the old battery first and connect the negative cable to the new battery last
- Connecting a battery charger - remove the battery from the welder by disconnecting the negative cable first, then the positive cable and battery clamp. When reinstalling, connect the negative cable last.
- Using a booster - connect the positive lead to the battery first, then connect the negative lead to the ground lead on the base.

To prevent ELECTRICAL DAMAGE when:

- Installing a new battery.
- Using a booster.

Use correct polarity - Negative Ground.

- To prevent **BATTERY DISCHARGE**, if you have an ignition switch, turn it off when engine is not running.
- To prevent **BATTERY BUCKLING**, tighten nuts on battery clamp until snug.

The Pipeliner 200D is equipped with a wet charged battery. The charging current is automatically regulated when the battery is low (after starting the engine) to a trickle current when the battery is fully charged.

When replacing, jumping, or otherwise connecting the battery to the battery cables the proper polarity must be observed. The correct polarity is **NEGATIVE GROUND.**

SAFETY PRECAUTIONS

⚠ WARNING

Do not attempt to use this equipment until you have thoroughly read the engine manufacturer's manual supplied with your welder. It includes important safety precautions, detailed engine starting, operating and maintenance instructions, and parts lists.



ELECTRIC SHOCK can kill.

- Do not touch electrically live parts or electrode with skin or wet clothing.
- Insulate yourself from work and ground
- Always wear dry insulating gloves.



ENGINE EXHAUST can kill.

- Use in open, well ventilated areas or vent exhaust outside.



MOVING PARTS can injure.

- Do not operate with doors open or guards off.
- Stop engine before servicing.
- Keep away from moving parts.

See additional warning information at front of this operator's manual.

Operate the welder with the doors closed. Leaving the doors open changes the designed air flow and can cause overheating.

GENERAL DESCRIPTION

The Pipeliner 200D is a heavy duty engine driven DC arc welding power source capable of providing DC constant current output for stick welding and DC TIG welding. With the addition of the optional Wire Feed Module the Pipeliner 200D will provide constant voltage output for running the LN-25 wire feeder.

The optional Remote Control Kit provides a remote control rheostat for remote fine current and open circuit voltage adjustment.

The Pipeliner 200D has Diesel Engine Protection. In the event of sudden low oil pressure or high coolant temperature, the engine immediately shuts down.

The Pipeliner 200D has a current range of 40-300 DC amps with output ratings as follows:

RATED OUTPUT	DUTY CYCLE
200A @ 28V	60%
200A @ 40V	60%

The unit is also capable of providing 1.80 kw of 120V DC auxiliary power at 35% duty cycle maximum.

This unit uses the PERKINS 104.22 Industrial water cooled diesel engine.

DESIGN SUMMARY

Control Panel

Both the engine and the welder controls are located on one recessed panel at the exciter end of the machine. The welder controls consist of a five step "Current Range Selector" switch and a "Fine Current Adjustment" rheostat. The welder is equipped with a "Start" button, "Glow Plug" button, "Ignition" switch, "Idler" control switch, hour meter, "Engine Protection" indicator light, "Remote / Local Switch and Receptacle" a battery charging ammeter, an oil pressure gauge and engine coolant temperature gauge.

The control panel also contains a three prong grounding type receptacle for auxiliary power.

Welding Generator

The Pipeliner 200D uses the old style, round, all copper FJW Generator frame which provides the customer with the original "Classic" pipe welding arc.

Engine Idler

The Pipeliner 200D is equipped with an electronic automatic engine idler. It automatically increases and decreases engine speed when starting and stopping welding or using auxiliary power. A built-in time delay permits changing electrodes before the engine slows to its low idle speed. The "Idler" control switch on the panel locks the idler in the full speed position when desired.

Auxiliary Power

1.80 kw of nominal 120V DC auxiliary power at 35% duty cycle maximum. Output voltage is maintained within $\pm 10\%$ at all loads up to rated capacity.

Welder Enclosure

The complete welder is rubber mounted on a rugged steel "C" channel base.

The output terminals are placed at the side of the machine so that they are protected by the door. The output terminals are labeled (+) and (-).

PIPELINER 200D



Cranking System

A 12V electric starter is standard.

Air Cleaner

Heavy duty two-stage dry type

Exhaust

A muffler and stainless steel exhaust outlet pipe are standard.

Engine Hour Meter

A meter to record the hours of operation.

ENGINE OPERATION

Operate the welder with the doors closed. Leaving the doors open changes the designed air flow and can cause overheating.

STARTING THE PIPELINER 200D PERKINS 104.22 DIESEL ENGINE

1. Turn the "IDLER" switch to "HIGH".
2. Turn the "IGNITION" switch to "ON".
3. Press the Glow Plug button for 20 to 30 seconds. (maximum 60 seconds).
4. Press the Start button. When the engine starts running, release both buttons. If the engine fails to start in 20 seconds, wait 30 seconds and repeat the above procedure.
5. Observe the oil pressure. If no pressure shows within 30 seconds, stop the engine and consult the engine operating manual. To stop the engine, turn the "IGNITION" switch to "OFF".
6. If the engine protection warning light comes on during cranking or after start up, the "IGNITION" switch must be turned "OFF" to reset the engine protection system.
7. Allow the engine to run at high idle speed for several minutes to warm the engine. Stop the engine and recheck the oil level after allowing sufficient time for the oil drain into the pan. If the level is down, fill it to the full mark again. The engine controls were properly set at the factory and should require no adjusting when received.

COLD WEATHER STARTING

With a fully charged battery and a proper weight oil, the engine should start satisfactorily even down to about -15°F (-26°C). If the engine must be frequently started at or below -15°F (-26°C), it may be desirable to install cold-starting aides.

Note: Extreme cold weather starting may require longer glow plug operation

 **WARNING**

Under NO conditions should ether or other starting fluids be used!

STOPPING the ENGINE

1. Turn the "IGNITION" switch to "OFF"

At the end of each day's welding, check the crankcase oil level, drain accumulated dirt and water from the sediment bowl under the fuel tank and refill the fuel tank to minimize moisture condensation in the tank. Also, running out of fuel tends to draw dirt into the fuel system.

When hauling the welder between job sites, close the fuel feed valve beneath the fuel tank.

If the fuel supply is cut off or runs out while the fuel pump is operating, air may be entrapped in the fuel distribution system. If this happens, bleeding of the fuel system may be necessary. Use qualified personnel to do this per the instructions in the MAINTENANCE section of this manual.

PIPELINER 200D WITH PERKINS 104.22 DIESEL ENGINE**TYPICAL FUEL CONSUMPTION DATA**

Low idle (1400 RPM) No Load	.33gal/hr (1.25ltrs/hr)
High idle (1800 Rpm) No load	.39gal/hr (1.48ltrs/hr)
200 Amps @ 28 Volts	.67gal/hr (2.54ltrs/hr)
200 Amps @ 40 Volts	.75gal/hr (2.84ltrs/hr)
Auxiliary Power 15 Amps @ 120 Volts	.50gal/hr (1.89ltrs/hr)

ENGINE BREAK-IN

Lincoln Electric selects high quality, heavy-duty industrial engines for the portable welding machines we offer. While it is normal to see a small amount of crankcase oil consumption during initial operation, excessive oil use, wetstacking (oil or tar like substance at the exhaust port), or excessive smoke is not normal.

Larger machines with a capacity of 350 amperes and higher, which are operated at low or no-load conditions for extended periods of time are especially susceptible to the conditions described above. To accomplish successful engine break-in, most diesel-powered equipment needs only to be run at a reasonably heavy load within the rating of the welder for some period of time during the engine's early life. However, if the welder is subjected to extensive light loading, occasional moderate to heavy loading of the engine may sometimes be necessary. Caution must be observed in correctly loading a diesel/generator unit.

1. Connect the welder output studs to a suitable resistive load bank. Note that any attempt to short the output studs by connecting the welding leads together, direct shorting of the output studs, or connecting the output leads to a length of steel will result in catastrophic damage to the generator and voids the warranty.
2. Set the welder controls for an output current and voltage within the welder rating and duty cycle. Note that any attempt to exceed the welder rating or duty cycle for any period of time will result in catastrophic damage to the generator and voids the warranty.
3. Periodically shut off the engine and check the crankcase oil level.

WELDER OPERATION

⚠ WARNING



ELECTRIC SHOCK can kill.

- Do not touch electrically live parts or electrode with skin or wet clothing.
- Insulate yourself from work and ground.



FUMES & GASES can be dangerous.

- Keep your head out of the fumes.
- Use ventilation or exhaust to remove fumes from breathing zone.



WELDING SPARKS can cause fire or explosion.

- Keep flammable material away.



ARC RAYS can burn.

- Wear eye, ear, and body protection.

DUTY CYCLE

The NEMA output rating of the Pipeliner 200D is 200 amperes at 28⁽¹⁾ arc volts on a 60% duty cycle. Duty cycle is based on a ten minute period; thus, the welder can be loaded at rated output for six minutes out of every ten minute period.

- (1) The "Lincoln Plus" output rating at 60% duty cycle is 200 amperes at 40 Volts.

CONTROL OF WELDING CURRENT

DO NOT TURN THE "CURRENT RANGE SELECTOR" WHILE WELDING because the current may arc between the contacts and damage the switch.

⚠ CAUTION

The "Current Range Selector" provides five overlapping current ranges. The "Fine Current Adjustment" adjusts the current from minimum to maximum within each range. Open circuit voltage is also controlled by the "Fine Current Adjustment" permitting control of the arc characteristics.

A high open circuit voltage setting provides the soft "buttering" arc with the best resistance to pop-outs preferred for most welding. To get this characteristic, set the "Current Range Selector" to the lowest setting that still provides the current you need and set the "Fine Current Adjustment" near maximum. For example: to obtain 175 amps and a soft arc, set the "Current Range Selector" to the 190-120 position and then adjust the "Fine Current Adjustment" for 175 amps.

PIPELINER 200D



When a forceful “digging” arc is required, usually for vertical and overhead welding, use a higher “Current Range Selector” setting and lower open circuit voltage. For example: to obtain 175 amps and a forceful arc, set the “Current Range Selector” to the 240-160 position and the “Fine Current Adjustment” setting to get 175 amps.

CAUTION



DO NOT attempt to set the “Current Range Selector” between the five points designated on the nameplate.

These switches have a spring loaded cam which almost eliminates the possibility of setting this switch between the designated points.

IDLER OPERATION

Start the engine with the “Idler” switch in the “High” position. Allow it to run at high idle speed for several minutes to warm the engine. See Specifications for operating speeds.

The idler is controlled by the “Idler” toggle switch on the welder control panel. The switch has two positions as follows:

1. In the “High”  position, the idler solenoid activates, and the engine goes to high idle speed. The speed is controlled by the governor.
2. In the “Auto”  /  position, the idler operates as follows:
 - When welding or drawing power for lights or tools (approximately 100-150 watts minimum) from the receptacle, the idler solenoid activates and the engine operates at high idle speed.
 - When welding ceases or the power load is turned off, a preset time delay of about 15 seconds starts. This time delay cannot be adjusted.
 - If the welding or power load is not re-started before the end of the time delay, the idler solenoid deactivates and reduces the engine to low idle speed.

AUXILIARY POWER

1.80 kW of 120V DC auxiliary power at 35% duty cycle maximum is available at the receptacle located on the control panel.

OPTIONAL FEATURES (Field Installed)

Accessory Set (K704) - Includes electrode and work cables, headshield, work clamp and electrode holder.

Remote Control Kit (K924-5) - Contains a remote control rheostat and 100 ft (30.5m) cable for adjusting the OCV at the welding site.

Remote Control Kit (K2464-1) - Contains a remote control rheostat (for adjusting CC "STICK" OCV), remote control potentiometer (for adjusting CV "STICK" OCV) and 100ft. (30.5m) cable.
(See Wiring/Connection Diagram Section)

Trailer (K957-1) - Two-wheeled trailer for in-plant and yard towing at speeds under 20 mph only.

Trailer (K953-1) - Two-wheeled trailer with optional fender and light package. For highway use, consult applicable federal, state, and local laws regarding possible additional requirements. Choice of 2 hitches and add on fender & light package. **Order: K953-1 Trailer, K958-1 Ball Hitch, K958-2 Lunette Eye Hitch, K959-1 Fender & Light Kit.**

 **WARNING**

Pipe Thawing with an arc welder can cause fire, explosion, damage to electric wiring or to the arc welder if done improperly. The use of an arc welder for pipe thawing is not approved by the CSA, nor is it recommended or supported by Lincoln Electric.

Wire Feed Module (K623-1) - Provides constant voltage (CV) output with improved arc stability for Innershield welding. Excellent for MIG welding. Recommended wire feeders are the LN-7, LN-23P and LN-25.

Spark Arrestor Kit (K903-1) - Includes a heavy gage steel, approved spark arrestor, clamp and adapter for mounting to the muffler exhaust pipe.

Oil Drain Kit (K1586-1) - Includes ball valve, hose and clamp.

SAFETY PRECAUTIONS

WARNING

Have qualified personnel do the maintenance work. Turn the engine off before working inside the machine. In some cases, it may be necessary to remove safety guards to perform required maintenance. Remove guards only when necessary and replace them when the maintenance requiring their removal is complete. Always use the greatest care when working near moving parts.

Do not put your hands near the engine cooling blower fan. If a problem cannot be corrected by following the instructions, take the machine to the nearest Lincoln Field Service Shop.



ELECTRIC SHOCK can kill.

- Do not touch electrically live parts or electrode with skin or wet clothing.
- Insulate yourself from work and ground
- Always wear dry insulating gloves.



ENGINE EXHAUST can kill.

- Use in open, well ventilated areas or vent exhaust outside.



MOVING PARTS can injure.

- Do not operate with doors open or guards off.
- Stop engine before servicing.
- Keep away from moving parts.

See additional warning information at front of this operator's manual.

4. When necessary, remove the sediment bowl from beneath the gas tank and clean out any accumulated dirt and water. Replace the fuel filter in the fuel line as needed.
5. See the engine manufacturers operation manual for detailed engine maintenance and troubleshooting instructions.

COOLING SYSTEM

The Pipeliner 200D is equipped with a pressure radiator. Keep the radiator cap tight to prevent loss of coolant. Clean and flush the cooling system periodically to prevent clogging the passage and overheating the engine. When antifreeze is needed, always use the permanent type.

ENGINE MAINTENANCE

Refer to the Engine's operation and maintenance manual for additional information on the engine.

GENERAL INSTRUCTIONS

1. Blow out the welder and controls with an air hose at least once every two months. In particularly dirty locations, this cleaning may be necessary once a week. Use low pressure air to avoid driving dirt into the insulation.
2. "Current Range Selector" contacts should not be greased. To keep the contacts clean, rotate the current control through its entire range frequently. Good practice is to turn the handle from maximum to minimum setting twice each morning before starting to weld.
3. Put a drop of oil on the "Current Range Selector" shaft at least once every month.

BEARINGS

This welder is equipped with a double-shielded ball bearing having sufficient grease to last indefinitely under normal service. Where the welder is used constantly or in excessively dirty locations, it may be necessary to add one-half ounce of grease per year. A pad of grease one inch wide, one inch long, and one inch high weighs approximately one-half ounce. Over-greasing is far worse than insufficient greasing.

When greasing the bearings, keep all dirt out of the area. Wipe the fittings completely clean and use clean equipment. More bearing failures are caused by dirt introduced during greasing than from insufficient grease.

COMMUTATOR AND BRUSHES

⚠ WARNING

Uncovered rotating equipment can be dangerous. Use care so your hands, hair, clothing or tools do not catch in the rotating parts. Protect yourself from particles that may be thrown out by the rotating armature when stoning the commutator.

The generator brushes are properly adjusted when the welder is shipped. They require no particular attention. **DO NOT SHIFT THE BRUSHES** or adjust the rocker setting. Shifting of the brushes may result in:

- Change in machine output
- Commutator damage
- Excessive brush wear

Periodically inspect the commutator and brushes by removing the covers. **DO NOT** remove or replace these covers while the machine is running.

Commutators require little attention. However, if they are black or appear uneven, have them cleaned by an experienced maintenance man using fine sandpaper or a commutator stone. Never use emery cloth or paper for this purpose.

Replace brushes when they wear within 1/4" of the pigtail. A complete set of replacement brushes should be kept on hand. Lincoln brushes have a curved face to fit the commutator. Have an experienced maintenance man seat these brushes by lightly stoning the commutator as the armature rotates at full speed until contact is made across the full face of the brushes. After stoning, blow out the dust with low pressure air.

Arcing or excessive exciter brush wear indicates a possible misaligned shaft. Have an authorized Field Service Shop check and realign the shaft.

IDLER MAINTENANCE

⚠ CAUTION

Before doing electrical work on the idler printed circuit board, disconnect the battery.

When installing a new battery or using a jumper battery to start the engine, be sure the battery polarity is connected properly. The correct polarity is **negative** ground. Damage to the engine alternator and the printed circuit board can result from incorrect connection.

1. The solenoid plunger must work freely and not bind. Dust the plunger about once a year with graphite powder.
2. Proper operation of the idler requires good grounding of the printed circuit board, current sensor and battery.
3. Idler solenoid is activated for high idle.
4. If desired, the welder can be used without automatic idling by setting the "Idler" switch to the "High" position.

NAMEPLATES

Whenever routine maintenance is performed on this machine - or at least yearly - inspect all nameplates and labels for legibility. Replace those which are no longer clear. Refer to the parts list for the replacement item number.

PURGING AIR from FUEL SYSTEM (Perkins 104.22 Engine)

Keep fuel clear of open flames or arcs, allow engine to cool before working on the fuel system. Wipe up any spilled fuel and do not start engine until fumes clear.

If the engine is running rough and you suspect air has been trapped in the fuel system, (EG. the engine was allowed to run out of fuel) perform the following steps using qualified personnel:

1. Loosen by two or three turns, the vent screw (Figure D.1) on the fuel inlet connection.
2. Operate the electric fuel pump by turning the "Ignition" switch "ON" until fuel, free of air, flows from the vent point. Tighten the vent screw.
3. Contact your Perkins Engine repair facility if problems persist.

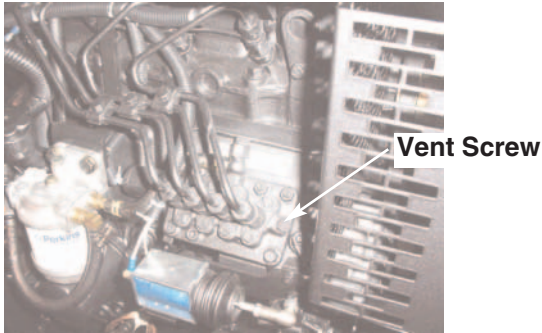

FIGURE D.1

ENGINE SERVICE

EVERY DAY OR EVERY 8 HOURS						
FIRST SERVICE-(20 / 50 HOURS)						
EVERY 100 HOURS OR 3 MONTHS						
EVERY 200 HOURS OR 6 MONTHS						
EVERY 400 HOURS OR 12 MONTHS						
EVERY 600 HOURS OR 18 MONTHS						
ENGINE SERVICE (NOTE 2)						
					MAINTENANCE ITEM	TYPE OR QUANTITY
I					Coolant level	
			I		Concentration of antifreeze	50/50 Water/Ethylene Glycol
			R		Coolant (NOTE 3)	9.5qrts., 9.0L
I					Engine oil level (NOTE 1)	
	R	R			Engine oil (NOTE 1 & 3)	8.7qrts, 8.2L (including filter)
	R	R			Engine oil filter	Perkins #140517000
	C	C			Drain water separator & fuel strainer	
			R		Fuel filter canister	Perkins #26560017
I					Tension of alternator drive belt	
			I		Alternator drive belt wear	
			R		Alternator drive belt	Perkins #080109080
	C	C			Air filter (earlier check may be req'd.)	
			R		Air filter element	Donaldson #P181050, Nelson #70206N
		I			Check and adjust idle speed	
			I		Tighten cylinder head	
			I		Valve clearances	Intake .008", exhaust .008"
			I		Electrical systems	
			I		All nuts and bolts for tightness	
			I		Injector performance	Contact Perkins
I					Leaks or engine damage	
			I		Battery	

I = Inspect C = Clean R = Replace

Notes:

- (1) Consult Engine Operators Manual for oil recommendations.
- (2) Consult Engine Operators Manual for additional maintenance schedule information.
- (3) Fill slowly! Ensure correct quantity is used.

Above operations to be carried out by trained personnel with reference to the workshop manual where necessary. These preventive maintenance periods apply to average conditions of operation. If necessary use shorter periods.

S25557

HOW TO USE TROUBLESHOOTING GUIDE

⚠ WARNING

Service and Repair should only be performed by Lincoln Electric Factory Trained Personnel. Unauthorized repairs performed on this equipment may result in danger to the technician and machine operator and will invalidate your factory warranty. For your safety and to avoid Electrical Shock, please observe all safety notes and precautions detailed throughout this manual.

This Troubleshooting Guide is provided to help you locate and repair possible machine malfunctions. Simply follow the three-step procedure listed below.

Step 1. LOCATE PROBLEM (SYMPTOM).

Look under the column labeled "PROBLEM (SYMPTOMS)". This column describes possible symptoms that the machine may exhibit. Find the listing that best describes the symptom that the machine is exhibiting.

Step 2. POSSIBLE CAUSE.

The second column labeled "POSSIBLE CAUSE" lists the obvious external possibilities that may contribute to the machine symptom.

Step 3. RECOMMENDED COURSE OF ACTION

This column provides a course of action for the Possible Cause, generally it states to contact your local Lincoln Authorized Field Service Facility.

If you do not understand or are unable to perform the Recommended Course of Action safely, contact your local Lincoln Authorized Field Service Facility.



ELECTRIC SHOCK can kill.

- Do not touch electrically live parts such as output terminals or internal wiring.



ENGINE EXHAUST can kill.

- Use in open, well ventilated areas or vent exhaust outside.



MOVING PARTS can injure.

- Do not operate with doors open or guards off.
 - Stop engine before servicing.
 - Keep away from moving parts.
- Remove guards only when necessary and replace when work requiring removal is complete.
 - Only qualified personnel should install, use or service this equipment.

⚠ CAUTION

If for any reason you do not understand the test procedures or are unable to perform the tests/repairs safely, contact your **Local Lincoln Authorized Field Service Facility** for technical troubleshooting assistance before you proceed.

PIPELINER 200D



Observe all Safety Guidelines detailed through out this manual

PROBLEMS (SYMPTOMS)	POSSIBLE AREAS OF MISADJUSTMENTS	RECOMMENDED COURSE OF ACTION
PROBLEMS		
Machine fails to hold the heat constantly.	<ol style="list-style-type: none"> 1. Rough or dirty commutator. 2. Brushes may be worn down to limit. 3. Field circuit may have variable resistance connection or intermittent open circuit due to loose, or broken wire. 4. Electrode lead or work lead connection may be poor. 5. Wrong grade of brushes may have been installed on generator. 6. Field rheostat may be making poor contact and overheating. 	<p>If all recommended possible areas of misadjustment have been checked and the problem persists, Contact your local Lincoln Authorized Field Service Facility.</p>
Welder starts but fails to generate current.	<ol style="list-style-type: none"> 1. Generator or exciter brushes may be loose or missing. 2. Exciter may not be operating. 3. Field circuit of generator or exciter may be open. 4. Exciter may have lost excitation. 5. Series field and armature circuit may be open-circuited. 	
Welding arc is loud and spatters excessively.	<ol style="list-style-type: none"> 1. Current setting may be too high. 2. Polarity may be wrong. 	

 **CAUTION**

If for any reason you do not understand the test procedures or are unable to perform the tests/repairs safely, contact your **Local Lincoln Authorized Field Service Facility** for technical troubleshooting assistance before you proceed.

PIPELINER 200D



Observe all Safety Guidelines detailed through out this manual

PROBLEMS (SYMPTOMS)	POSSIBLE AREAS OF MISADJUSTMENTS	RECOMMENDED COURSE OF ACTION
PROBLEMS		
Welding current too great or too small compared to indication on the dial.	<ol style="list-style-type: none"> 1. Exciter output low causing low output compared to dial indication. 2. Operating speed too low or high. 	If all recommended possible areas of misadjustment have been checked and the problem persists, Contact your local Lincoln Authorized Field Service Facility.
Arc continuously pops out.	<ol style="list-style-type: none"> 1. "Current Range Selector" switch may be set at an intermediate position. 	

Flashing the exciter field consists of passing current through the fields using an external source of 6 to 125 volts of DC power from a storage battery or DC generator. If using a DC generator, keep the generator turned off except when actually applying the flashing current. To flash the fields:

1. Turn the welder off. Raise one exciter brush off the commutator.
2. On Lincoln welders, attach the positive lead from the external DC source to the right hand brushholder.
3. Carefully holding an insulated section of the negative lead from the DC source, touch its lug or clamp to the left hand brushholder for five seconds. Pull it away quickly to minimize arcing.

Remove the lead from the right hand brushholder, replace the brush on the commutator, start the welder and the generator voltage should build up.

CAUTION

If for any reason you do not understand the test procedures or are unable to perform the tests/repairs safely, contact your **Local Lincoln Authorized Field Service Facility** for technical troubleshooting assistance before you proceed.

Observe all Safety Guidelines detailed throughout this manual

PROBLEMS (SYMPTOMS)	POSSIBLE AREAS OF MISADJUSTMENTS	RECOMMENDED COURSE OF ACTION
Engine does not start or operates Irregularly	<ol style="list-style-type: none"> 1. Faulty Ignition switch and or Injector pump solenoid 2. Insufficient charging or complete discharge of the battery 3. Lack of fuel 4. Air mixed in the fuel system. 5. Clogged fuel filter 6. Irregular and faulty fuel supply (Injector pump trouble) 7. Glow plug not heated 8. Improper viscosity of the lubricating oil 9. Clogged air cleaner 10. No compression 11. Engine protection light is on 12. Defective governor 13. Engine defective 	<p>If all recommended possible areas of misadjustment have been checked and the problem persists, Contact your local Lincoln Authorized Field Service Facility.</p>
Engine stops during operation and the Engine Protection light does not turn on	<ol style="list-style-type: none"> 1. Lack of fuel 2. Clogged fuel filter 3. Air mixed in the fuel system 4. Faulty function of the engine 	
Engine stops during operation and the Engine Protection light does turn on	<ol style="list-style-type: none"> 1. Overheating of the engine <ul style="list-style-type: none"> • Lack of coolant • Loose or damaged fan belt • Clogged radiator • Dust or scale clogged in the cooling water passages • Faulty thermostat • Lack of oil • Overloading • Faulty Idler/Engine Protection P.C. Board 2. Loss of engine oil pressure <ul style="list-style-type: none"> • Lack of engine oil • Faulty oil pressure switch • Oil leakage from the lubricating system • Clogged oil filter • Too low viscosity of the engine oil • Faulty Idler/Engine Protection P.C. Board 	

 **CAUTION**

If for any reason you do not understand the test procedures or are unable to perform the tests/repairs safely, contact your **Local Lincoln Authorized Field Service Facility** for technical troubleshooting assistance before you proceed.

PIPELINER 200D



Observe all Safety Guidelines detailed throughout this manual

PROBLEMS (SYMPTOMS)	POSSIBLE AREAS OF MISADJUSTMENTS	RECOMMENDED COURSE OF ACTION
White or Blue Smoke	<ol style="list-style-type: none"> 1. Excess engine oil 2. Too low viscosity of the engine oil 3. Faulty injection timing 	<p>If all recommended possible areas of misadjustment have been checked and the problem persists, Contact your local Lincoln Authorized Field Service Facility.</p>
Dark Grey Smoke	<ol style="list-style-type: none"> 1. Unsuitable fuel 2. Excess injection 3. Faulty function of the engine 4. Overloading 5. Clogged air cleaner 	
Faulty Charging	<ol style="list-style-type: none"> 1. Loose fan belt 2. Faulty wiring 3. Faulty battery 4. Worn out alternator brush 	
Starter Motor does not run	<ol style="list-style-type: none"> 1. Loose or damaged wiring 2. Dropped voltage of the battery 3. Damaged starter motor (including solenoid) 	
Engine Protection Light not coming on (after the ignition switch has been in the on position for more than 60 seconds with the engine not started)	<ol style="list-style-type: none"> 1. Broken Light Bulb 2. Faulty light wiring (to GND or P.C. Board) 3. Faulty Idler/Engine Protection P.C. Board 	

 **CAUTION**

If for any reason you do not understand the test procedures or are unable to perform the tests/repairs safely, contact your **Local Lincoln Authorized Field Service Facility** for technical troubleshooting assistance before you proceed.

PIPELINER 200D



ELECTRONIC IDLER TROUBLESHOOTING GUIDE

With Idler Control Switch in the Auto Position,
Engine Will Not Return to Low Idle in Approximately 15 Seconds
After Welding and Auxiliary Loads are Removed

Set Idler Control Switch
to the Auto Position

Check for Continuity through Idler
Control Switch

Open

Closed

Measure DC Voltage on
Idler Solenoid Coil

Replace Idler
Control Switch

12 VDC

0 VDC

Check Continuity of
Current sensor from Idler
PC Board Terminal
to Ground Terminal

Check for Jamming
of the Idler Solenoid
Mechanism or a broken
Return Spring

Open

Closed

1. Check Wiring in
Idler Solenoid
Circuit

Replace Current
Sensor

2. Replace Idler
P.C. Board

CAUTION

If for any reason you do not understand the test procedures or are unable to perform the tests/repairs safely, contact your **Local Lincoln Authorized Field Service Facility** for technical troubleshooting assistance before you proceed.

PIPELINER 200D



ELECTRONIC IDLER TROUBLESHOOTING GUIDE

With Idler Control Switch in the AUTO Position,
Engine Will Not Pick Up Speed When:

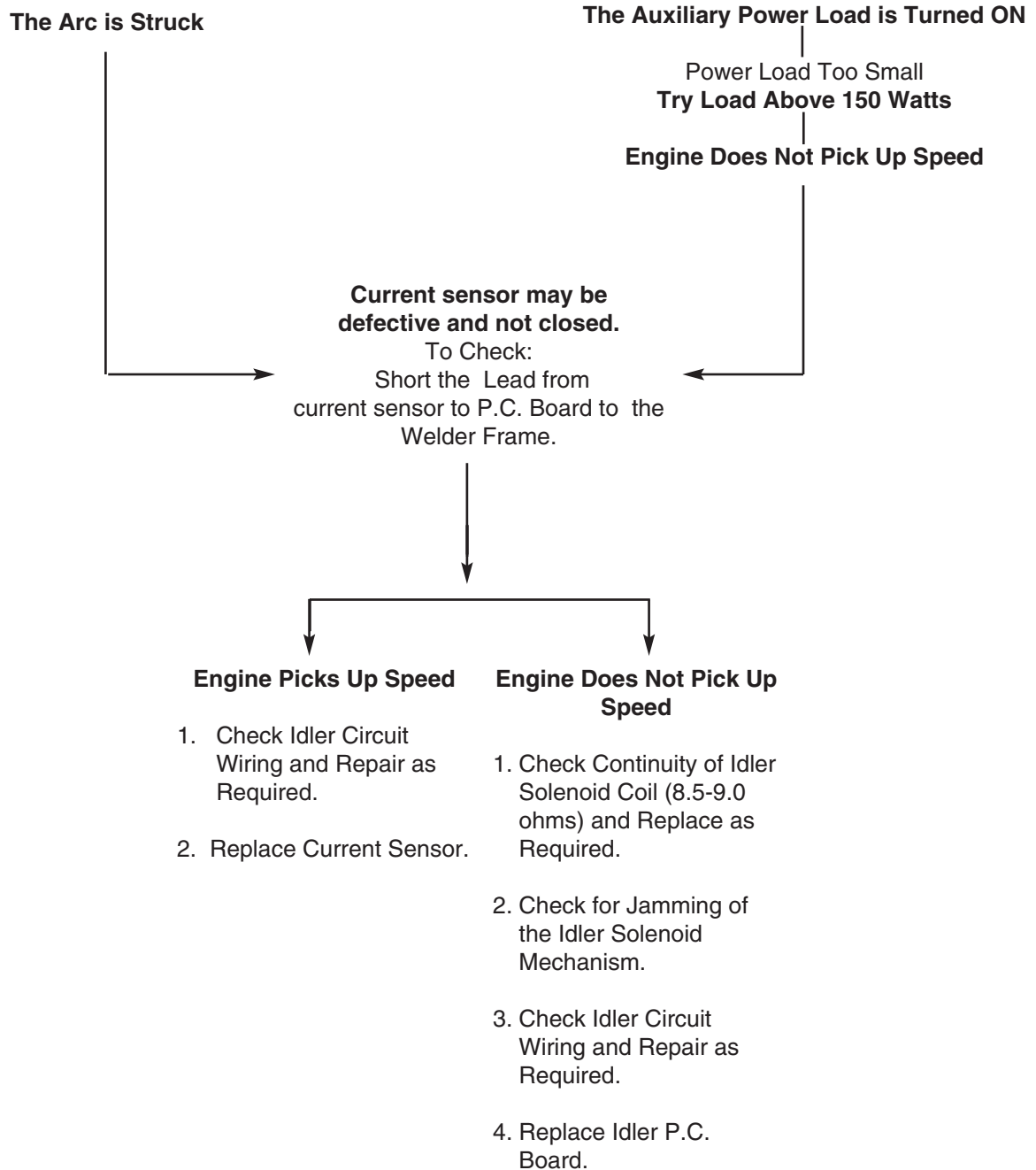

NOTE: If the engine will not idle up or down under both weld and auxiliary load, check idler circuit wiring. The direction of leads entering the current sensor may be incorrect.

CAUTION

If for any reason you do not understand the test procedures or are unable to perform the tests/repairs safely, contact your **Local Lincoln Authorized Field Service Facility** for technical troubleshooting assistance before you proceed.

PIPELINER 200D



PIPELINER 200D WIRING DIAGRAM

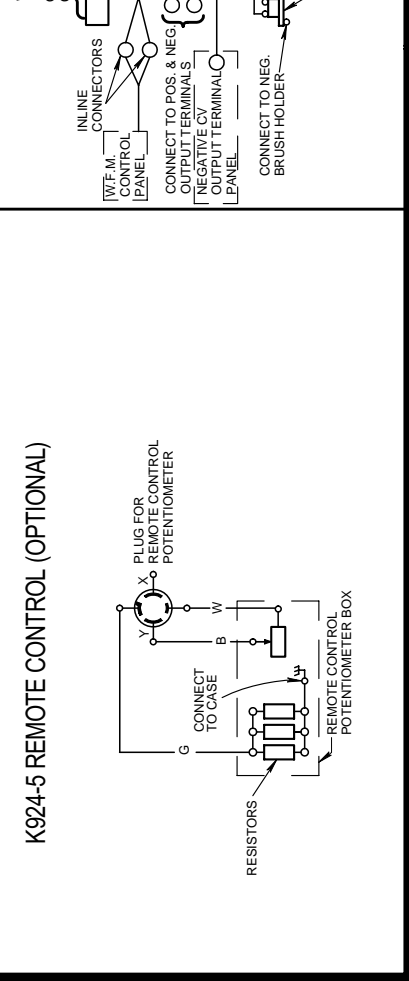
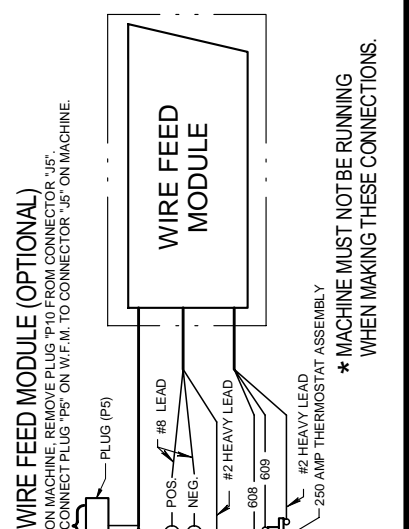
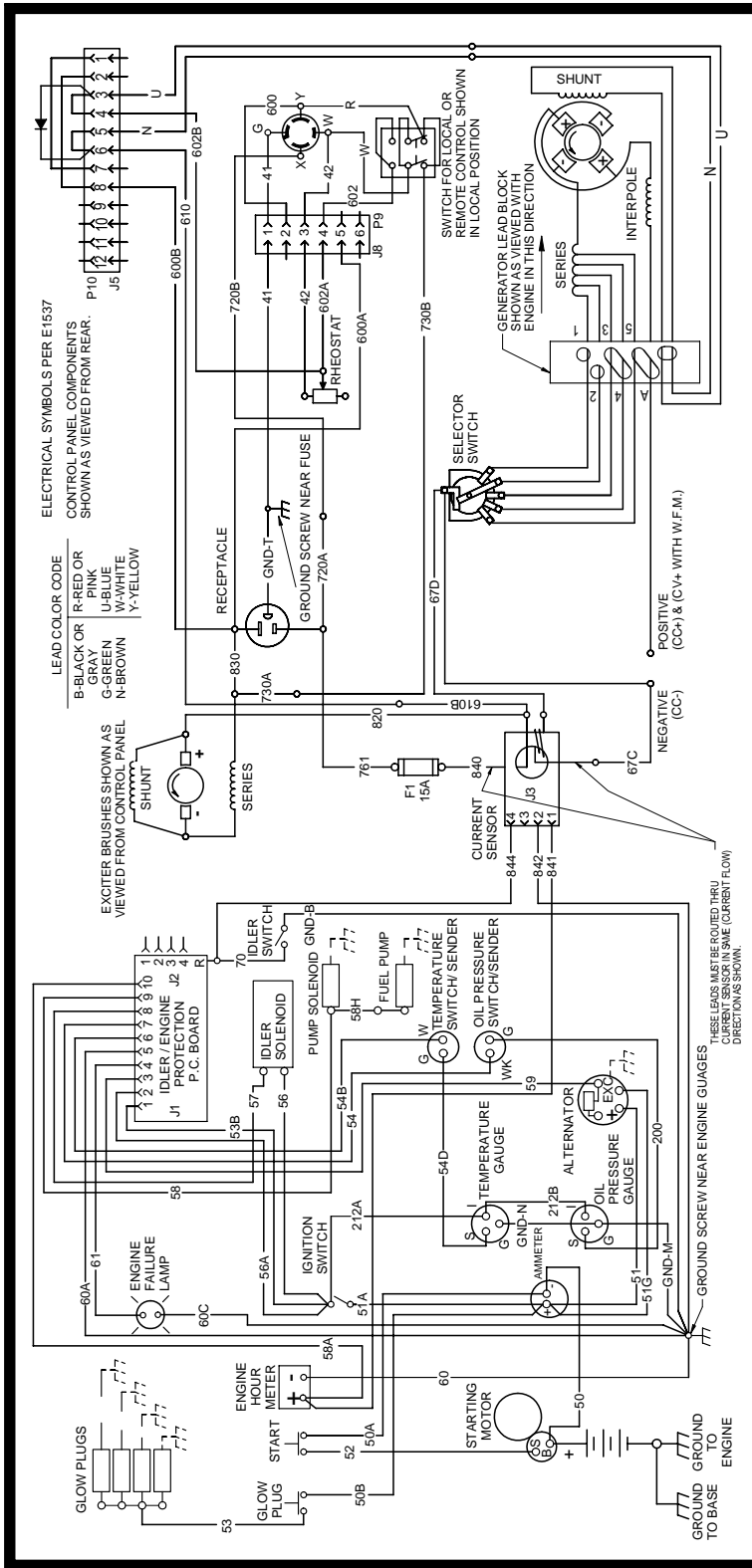

M20056

NOTE: This diagram is for reference only. It may not be accurate for all machines covered by this manual. The specific diagram for a particular code is pasted inside the machine on one of the enclosure panels. If the diagram is illegible, write to the Service Department for a replacement. Give the equipment code number.

K2464-1 REMOTE CONTROL WIRING / CONNECTION DIAGRAM

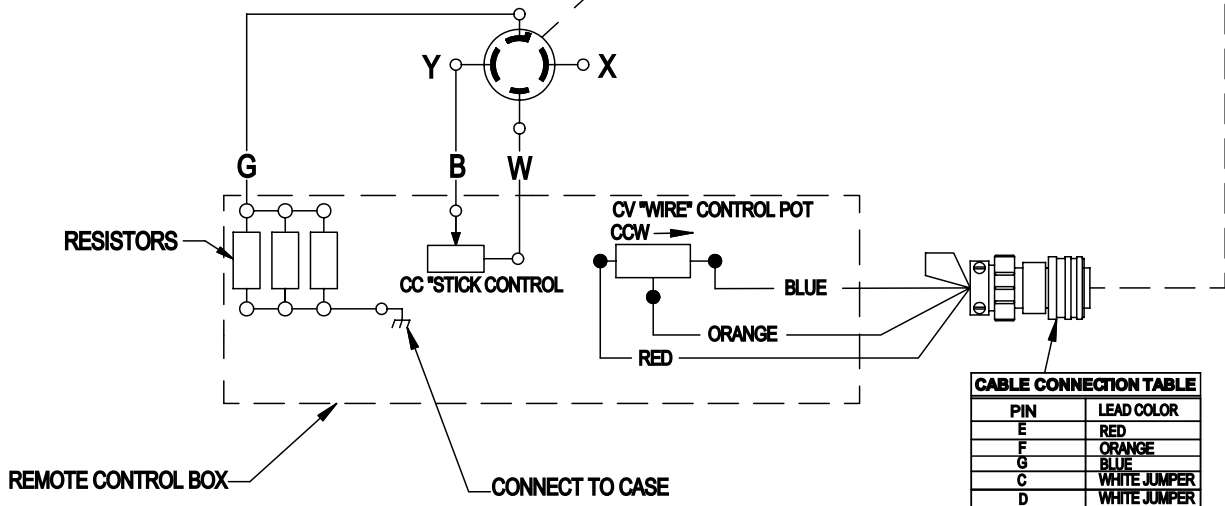
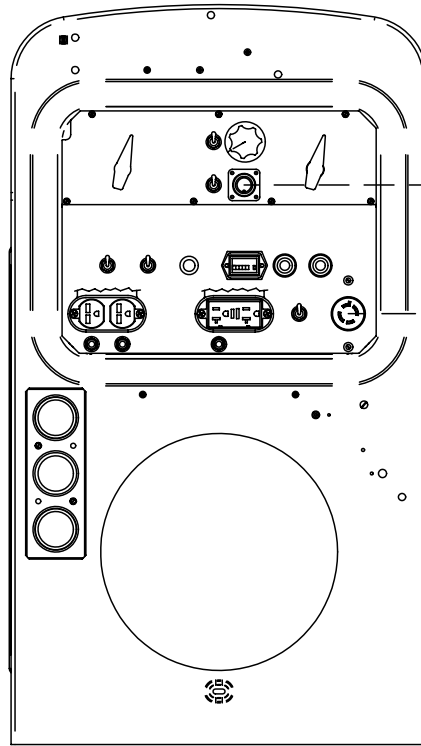

CABLE CONNECTION TABLE	
PIN	LEAD COLOR
E	RED
F	ORANGE
G	BLUE
C	WHITE JUMPER
D	WHITE JUMPER



THE LINCOLN ELECTRIC COMPANY

World's Leader in Welding and Cutting Products
 Sales and Service through Subsidiaries and Distributors Worldwide
 Cleveland, Ohio 44117-1199 U.S.A.

A.01

S26097

PIPELINER 200D



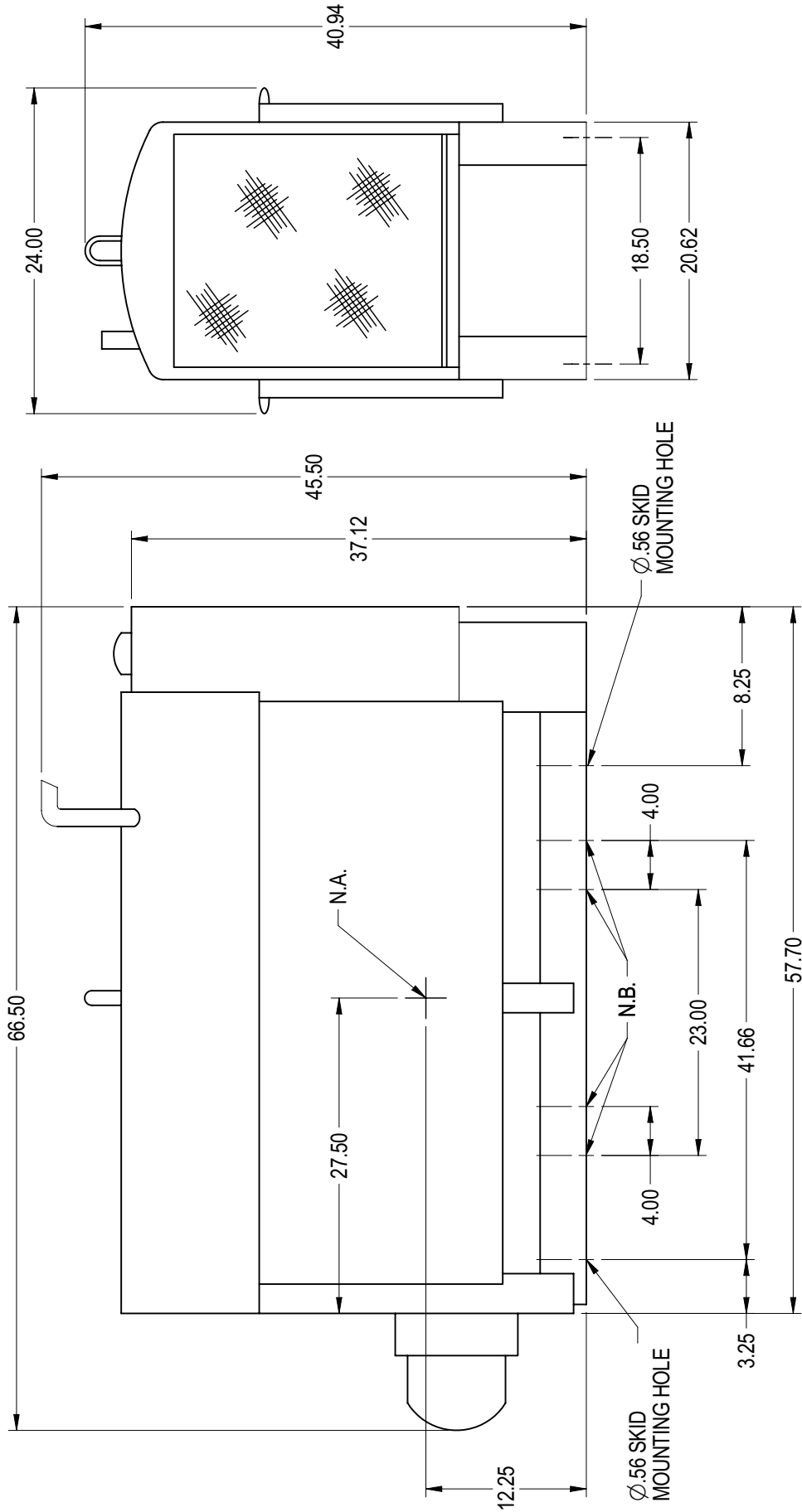

PIPELINER 200D



B

S10766-11

NOTES:
 N.A. CENTER OF GRAVITY WITH OIL AND WATER IN ENGINE, BUT NO FUEL.
 N.B. Ø.56 TRAILER MOUNTING HOLES.

NOTES

PIPELINER 200D



NOTES

PIPELINER 200D



WARNING	<ul style="list-style-type: none"> ● Do not touch electrically live parts or electrode with skin or wet clothing. ● Insulate yourself from work and ground. 	<ul style="list-style-type: none"> ● Keep flammable materials away. 	<ul style="list-style-type: none"> ● Wear eye, ear and body protection.
Spanish AVISO DE PRECAUCION	<ul style="list-style-type: none"> ● No toque las partes o los electrodos bajo carga con la piel o ropa mojada. ● Aíslese del trabajo y de la tierra. 	<ul style="list-style-type: none"> ● Mantenga el material combustible fuera del área de trabajo. 	<ul style="list-style-type: none"> ● Protéjase los ojos, los oídos y el cuerpo.
French ATTENTION	<ul style="list-style-type: none"> ● Ne laissez ni la peau ni des vêtements mouillés entrer en contact avec des pièces sous tension. ● Isolez-vous du travail et de la terre. 	<ul style="list-style-type: none"> ● Gardez à l'écart de tout matériel inflammable. 	<ul style="list-style-type: none"> ● Protégez vos yeux, vos oreilles et votre corps.
German WARNUNG	<ul style="list-style-type: none"> ● Berühren Sie keine stromführenden Teile oder Elektroden mit Ihrem Körper oder feuchter Kleidung! ● Isolieren Sie sich von den Elektroden und dem Erdboden! 	<ul style="list-style-type: none"> ● Entfernen Sie brennbares Material! 	<ul style="list-style-type: none"> ● Tragen Sie Augen-, Ohren- und Körperschutz!
Portuguese ATENÇÃO	<ul style="list-style-type: none"> ● Não toque partes elétricas e electrodos com a pele ou roupa molhada. ● Isole-se da peça e terra. 	<ul style="list-style-type: none"> ● Mantenha inflamáveis bem guardados. 	<ul style="list-style-type: none"> ● Use proteção para a vista, ouvido e corpo.
Japanese 注意事項	<ul style="list-style-type: none"> ● 通電中の電気部品、又は溶材にヒフやぬれた布で触れないこと。 ● 施工物やアースから身体が絶縁されている様にして下さい。 	<ul style="list-style-type: none"> ● 燃えやすいものの側での溶接作業は絶対にしてはなりません。 	<ul style="list-style-type: none"> ● 目、耳及び身体に保護具をして下さい。
Chinese 警告	<ul style="list-style-type: none"> ● 皮膚或濕衣物切勿接觸帶電部件及鎢條。 ● 使你自已與地面和工件絕緣。 	<ul style="list-style-type: none"> ● 把一切易燃物品移離工作場所。 	<ul style="list-style-type: none"> ● 佩戴眼、耳及身體勞動保護用具。
Korean 위험	<ul style="list-style-type: none"> ● 전도체나 용접봉을 젖은 헝겊 또는 피부로 절대 접촉치 마십시오. ● 모재와 접지를 접촉치 마십시오. 	<ul style="list-style-type: none"> ● 인화성 물질을 접근시키지 마십시오. 	<ul style="list-style-type: none"> ● 눈, 귀와 몸에 보호장구를 착용하십시오.
Arabic تحذير	<ul style="list-style-type: none"> ● لا تلمس الاجزاء التي يسري فيها التيار الكهربائي أو الألكترود بجسد الجسم أو بالملابس المبللة بالماء. ● ضع عازلا على جسمك خلال العمل. 	<ul style="list-style-type: none"> ● ضع المواد القابلة للاشتعال في مكان بعيد. 	<ul style="list-style-type: none"> ● ضع أدوات وملابس واقية على عينيك وأذنيك وجسمك.

READ AND UNDERSTAND THE MANUFACTURER'S INSTRUCTION FOR THIS EQUIPMENT AND THE CONSUMABLES TO BE USED AND FOLLOW YOUR EMPLOYER'S SAFETY PRACTICES.

SE RECOMIENDA LEER Y ENTENDER LAS INSTRUCCIONES DEL FABRICANTE PARA EL USO DE ESTE EQUIPO Y LOS CONSUMIBLES QUE VA A UTILIZAR, SIGA LAS MEDIDAS DE SEGURIDAD DE SU SUPERVISOR.

LISEZ ET COMPRENEZ LES INSTRUCTIONS DU FABRICANT EN CE QUI REGARDE CET EQUIPMENT ET LES PRODUITS A ETRE EMPLOYES ET SUIVEZ LES PROCEDURES DE SECURITE DE VOTRE EMPLOYEUR.

LESEN SIE UND BEFOLGEN SIE DIE BETRIEBSANLEITUNG DER ANLAGE UND DEN ELEKTRODENEINSATZ DES HERSTELLERS. DIE UNFALLVERHÜTUNGSVORSCHRIFTEN DES ARBEITGEBERS SIND EBENFALLS ZU BEACHTEN.

			
<ul style="list-style-type: none"> ● Keep your head out of fumes. ● Use ventilation or exhaust to remove fumes from breathing zone. 	<ul style="list-style-type: none"> ● Turn power off before servicing. 	<ul style="list-style-type: none"> ● Do not operate with panel open or guards off. 	WARNING
<ul style="list-style-type: none"> ● Los humos fuera de la zona de respiración. ● Mantenga la cabeza fuera de los humos. Utilice ventilación o aspiración para gases. 	<ul style="list-style-type: none"> ● Desconectar el cable de alimentación de poder de la máquina antes de iniciar cualquier servicio. 	<ul style="list-style-type: none"> ● No operar con panel abierto o guardas quitadas. 	Spanish AVISO DE PRECAUCION
<ul style="list-style-type: none"> ● Gardez la tête à l'écart des fumées. ● Utilisez un ventilateur ou un aspirateur pour ôter les fumées des zones de travail. 	<ul style="list-style-type: none"> ● Débranchez le courant avant l'entretien. 	<ul style="list-style-type: none"> ● N'opérez pas avec les panneaux ouverts ou avec les dispositifs de protection enlevés. 	French ATTENTION
<ul style="list-style-type: none"> ● Vermeiden Sie das Einatmen von Schweißrauch! ● Sorgen Sie für gute Be- und Entlüftung des Arbeitsplatzes! 	<ul style="list-style-type: none"> ● Strom vor Wartungsarbeiten abschalten! (Netzstrom völlig öffnen; Maschine anhalten!) 	<ul style="list-style-type: none"> ● Anlage nie ohne Schutzgehäuse oder Innenschutzverkleidung in Betrieb setzen! 	German WARNUNG
<ul style="list-style-type: none"> ● Mantenha seu rosto da fumaça. ● Use ventilação e exaustão para remover fumo da zona respiratória. 	<ul style="list-style-type: none"> ● Não opere com as tampas removidas. ● Desligue a corrente antes de fazer serviço. ● Não toque as partes elétricas nuas. 	<ul style="list-style-type: none"> ● Mantenha-se afastado das partes moventes. ● Não opere com os painéis abertos ou guardas removidas. 	Portuguese ATENÇÃO
<ul style="list-style-type: none"> ● ヒュームから頭を離すようにして下さい。 ● 換気や排煙に十分留意して下さい。 	<ul style="list-style-type: none"> ● メンテナンス・サービスに取りかかる際には、まず電源スイッチを必ず切ってください。 	<ul style="list-style-type: none"> ● パネルやカバーを取り外したまま機械操作をしないで下さい。 	Japanese 注意事項
<ul style="list-style-type: none"> ● 頭部遠離煙霧。 ● 在呼吸區使用通風或排風器除煙。 	<ul style="list-style-type: none"> ● 維修前切斷電源。 	<ul style="list-style-type: none"> ● 儀表板打開或沒有安全罩時不準作業。 	Chinese 警告
<ul style="list-style-type: none"> ● 얼굴로부터 용접가스를 멀리하십시오. ● 호흡지역으로부터 용접가스를 제거하기 위해 가스제거기나 통풍기를 사용하십시오. 	<ul style="list-style-type: none"> ● 보수전에 전원을 차단하십시오. 	<ul style="list-style-type: none"> ● 판넬이 열린 상태로 작동치 마십시오. 	Korean 위험
<ul style="list-style-type: none"> ● ابعد رأسك بعيداً عن الدخان. ● استعمل التهوية أو جهاز ضغط الدخان للخارج لكي تبعد الدخان عن المنطقة التي تتنفس فيها. 	<ul style="list-style-type: none"> ● أقطع التيار الكهربائي قبل القيام بأية صيانة. 	<ul style="list-style-type: none"> ● لا تشغيل هذا الجهاز اذا كانت الاغطية الحديدية الواقية ليست عليه. 	Arabic تحذير

LEIA E COMPREENDA AS INSTRUÇÕES DO FABRICANTE PARA ESTE EQUIPAMENTO E AS PARTES DE USO, E SIGA AS PRÁTICAS DE SEGURANÇA DO EMPREGADOR.

使う機械や溶材のメーカーの指示書をよく読み、まず理解して下さい。そして貴社の安全規定に従って下さい。

請詳細閱讀並理解製造廠提供的說明以及應該使用的銀焊材料，並請遵守貴方的有閣勞動保護規定。

이 제품에 동봉된 작업지침서를 숙지하시고 귀사의 작업자 안전수칙을 준수하시기 바랍니다.

اقرأ بتمعن وافهم تعليمات المصنع المنتج لهذه المعدات والمواد قبل استعمالها واتبع تعليمات الوقاية لصاحب العمل.



• World's Leader in Welding and Cutting Products •

• Sales and Service through Subsidiaries and Distributors Worldwide •

Cleveland, Ohio 44117-1199 U.S.A. TEL: 216.481.8100 FAX: 216.486.1751 WEB SITE: www.lincolnelectric.com