

H25/H50-EF STATIFLEX 300-M



H25/50-EF

This air cleaner is suitable for extracting welding fumes in situations where it is impossible to use an extraction arm at the source. The H25/50-EF is suitable for treating regular and oily welding fumes originating from oil treated steel.

The system is based on an electrostatic filter and has a built in fan.

For removing oil mist, the H25/H50-EF can be equipped with an oil mist eliminator as a prefilter. The unit is fitted as standard with an oil collector which can be fitted with a tap to drain the oil.



Statiflex 300-M

This unit is fitted with a multi-layer bag filter. This filter combines excellent efficiency with low air resistance. The SFM has been developed for applications with a low dust/welding fume load, such as TIG welding. Furthermore, the SFM is specially suited to be used as a backup filter after the SFE. If the electrostatic filter becomes clogged, the SFM, because of its low air resistance, ensures that filter efficiency is guaranteed.

ADVANTAGE

- ✓ Easy clean electrostatic filter system
- ✓ Collector surface area:
H25-EF: 14.2 m²
H50-EF: 28.4 m²
- ✓ Filter efficiency up to 99%
- ✓ Adjustable outlet grid
- ✓ Aluminium spark arrester
- ✓ Power consumption:
H25-EF: 0,75 kW
H50-EF: 1,5 kW
- ✓ Maximum capacity
H25-EF: 2500 m³/h
H50-EF: 5000 m³/h
- ✓ High voltage indicator light
- ✓ Fitted with an oil collector as standard
- ✓ Can optionally be fitted with an oil drain tap and various types of prefilters and final filters
- ✓ Fitted with an integrated fan
- ✓ Weight
H25-EF: 100 kg
H50-EF: 195 kg

ADVANTAGE

- ✓ Synthetic bag filter class F8
- ✓ Aluminium spark arrester
- ✓ Maximum capacity
Statiflex 300-M-1: 2500 m³/h
Statiflex 300-M-2: 5000 m³/h
- ✓ Weight
Statiflex 300-M-1: 44 kg
Statiflex 300-M-2: 66 kg

STATIFLEX 6000-MS

ADVANTAGE

- ✓ RotaPulsePlus® automatic filter cleaning
- ✓ Cartridge filter with ExtraCoat® treatment and 3-D pleating
- ✓ Filter surface area 150 m²
- ✓ Filter efficiency up to 99.8%
- ✓ To be installed with the optional heavy particle and spark pre-separator
- ✓ Compressed air connection 6 bar
- ✓ Compressed air consumption:
max. 150 NL/min
- ✓ Weight 250 kg
- ✓ Filter residue container: 100 litres
- ✓ Position air inlet: 8 options
Position air outlet: 2 options

The central filter unit Statiflex 6000-MS is capable of providing high efficiency filtration for up to 4 arms and SF 2400 fan combinations. If a greater capacity is required, several systems can easily be linked due to the modular construction method. The filter system can be used with several individual fans or one central fan. The system is based upon the patented RotaPulsePlus concept. This cleaning method gives the Statiflex 6000-MS a constantly high exhaust capacity, a low level of energy consumption and a longer filter life span. In addition to the extraction of welding fumes, it is also particularly suitable for connection to a cutting table.



The Netherlands
Lincoln Smitweld B.V.
P.O. Box 253
6500 AG Nijmegen
Tel: +31 24 3522 911
Fax: +31 24 3522 204

Belgium
Lincoln Smitweld Belgium S.A.
Paul Gilsonlaan 470
1620 Drogenbos
Tel: +32 2 37 70 071
Fax: +32 237 81 877

Germany
Lincoln Smitweld GmbH
Max-Keith-Strasse 39
45136 Essen
Tel: +49 201 8 96 280
Fax: +49 201 8 96 2831

Norway
Lincoln Electric Norge A.S.
Brobekkveien 38
P.O. Box 146 Alnabru
N-0614 Oslo
Tel: +47 23 37 74 00
Fax: +47 22 72 05 80

Denmark
Lincoln Electric Nordic
Frichsparken
Søren Frichs Vej 38D
8230 Åbyhøj
Tel: +45 86 26 51 00
Fax: +45 86 26 51 50

Sweden
Lincoln Electric Sverige AB
Lärkvägen 2
441 40 Allingsås
Tel: +46 322 781 30
Fax: +46 322 671 830



Finland
Lincoln Electric Finland
Mestarintie 4
27500 Kauttua
Tel: +358 10 522 3500
Fax: +358 10 522 3510

Croatia
Lincoln Croatia / Trea Trade d.o.o.
Blazici b.b
51 000 Rijeka
Tel: +385 51 683 400
Fax: +358 51 681 088

France
Lincoln Electric France S.A.
Avenue Franklin Roosevelt
76120 Le Grand-Quevilly
Tel: +33 232 11 40 40
Fax: +33 232 11 40 11

Italy
Lincoln Electric Italia S.r.l.
Via F.lli Canepa 8
16010 Serra Ricco, Genova
Tel: +39 010 754 111
Fax: +39 010 754 1150

Spain
Lincoln KD S.A.
Ctra. Laureà Miro 396-398
08980 Sant Feliu de Llobregat, Barcelona
Tel: +34 93 685 9600
Fax: +34 93 685 9610

England
Lincoln Electric (UK) Limited
Mansfield Road
Aston, Sheffield, S26 2BS
Tel: +44 114 287 2401
Fax: +44 114 287 2582

Czech Republic & Slovakia
Lincoln Electric
Nao KAJETTANKOU 29/1445
1 69 00 Praha 6,
Tel./Fax: +420 2333 55 409
Mobile: +420 606 61 61 65

Hungary
Lincoln Electric Hungarian
Representative Office
1239 Budapest
Haraszti ut 44
Tel.: +36 1 289 0980
Mob.: +36 30989 66 42
Fax: +36 1 286 0328

Lithuania
Lincoln Electric Lithuania
Stoties Str 3 – 1
5730 Silute
Tel/fax: +370 698 135 91

Romania, Serbia, Macedonia, Bulgaria
Lincoln Electric Europe
Calea Dorobantilor 111-131
Bloc 9C, Sc. E, Apt 151
Sector 1, 71224, Bucharest, Romania
Tel: +407 44 566 702
Mob.: +407 44 309 338
Fax: +402 12 308 381

Turkey
Akaynak
Yakacikalti, Ankara Asfalti
Yanyol Mermer Sok. No: 16 Kartal
81450 Istanbul,
Tel.: +902 163 773 090
Fax: +902 163 770 000

**LINCOLN
ELECTRIC**

www.lincolnelectric.com

LINCOLN ENVIRONMENTAL SYSTEMS



STATIONARY WELDING FUME EXTRACTORS



The extraction of welding fumes may cause an important loss of expensively heated air. In order to avoid this, the Pro Source stationary welding fume extractors filter the contaminated air and recirculate it into the work area. Incidentally, filtering the extracted welding fumes can also be necessary to satisfy the applicable emission standards.

The complete range of Pro Source stationary welding fume extraction units can be combined with various filter systems and extraction arms. As a result of this, there is a suitable stationary welding fume extraction solution for any type of welding area.

**LINCOLN
ELECTRIC**

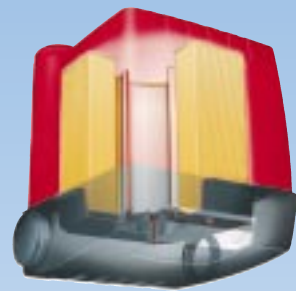

Mechanical filtering technique

The Lincoln Pro Source LongLife® filter has a filter surface of no less than 50 m². In combination with its special structure this results in a high filter efficiency, a long life span and low operational cost. The system is suitable for dry welding fumes.



Self-cleaning filtering technique

The Lincoln Pro Source RotaPulse® concept is a fully automatic mechanism which cleans the filter sections periodically through air pulses from a pressure vessel. This results in a constantly high extraction capacity. Through the ExtraCoat® treatment of the filter and its 30 m² surface, it has a highly efficient filter and a long life span. The system is suitable for dry welding fumes.

FILTERING TECHNIQUES



Electrostatic filtering technique

The electrostatic filter is made up of three sections i.e. a mechanical pre filter, an ioniser where the polluted particles are charged and a collector with an effective surface area of 14.2 m². The collector is equipped with electrically charged plates which attract the polluted particles. The purified air is re-circulated via an after filter. The system is particularly suitable for the extraction of welding fumes released during the processing of oil treated steel.

STATIFLEX 200-M MECHANICAL FILTER



Dimensions Statiflex 200-M

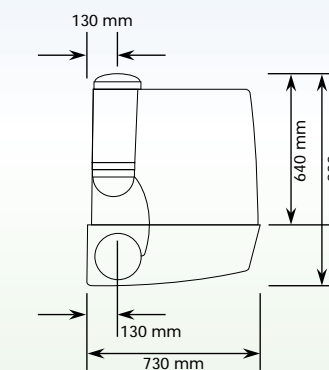
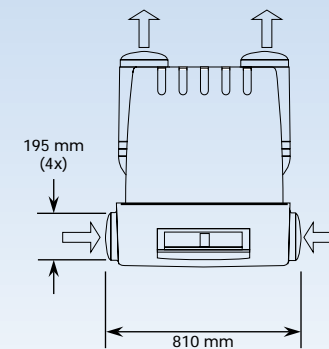

The heart of the Statiflex 200-M is the LongLife® filter with metal spark arrester. The combination of the filter surface (50 m²) and 3-D pleating, makes the dust collection capacity of this filter enormous.

The Statiflex 200-M can be combined with the extraction arms LFA 2.0/3.0/4.0/3.1 and 4.1. It is designed for infrequent to regular welding operations, where dry welding fumes are released.

A clogged filter indicator shows whether the extraction is still satisfactory or whether the filter needs to be replaced. The Statiflex 200-M can support a maximum of two welding workplaces.



ADVANTAGE

- ✓ LongLife® filter
- ✓ Filter surface area 50 m²
- ✓ Filter efficiency up to 99%
- ✓ Aluminium spark arrester
- ✓ Clogged filter indicator
- ✓ Suitable for a maximum of two extraction arms, each fitted with a SF 2400.
- ✓ Weight 30 kg

STATIFLEX 400-MS SELF-CLEANING FILTER



Dimensions Statiflex 400-MS

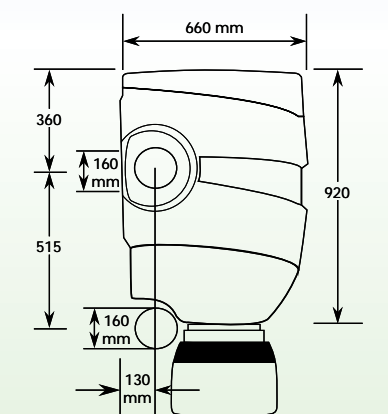
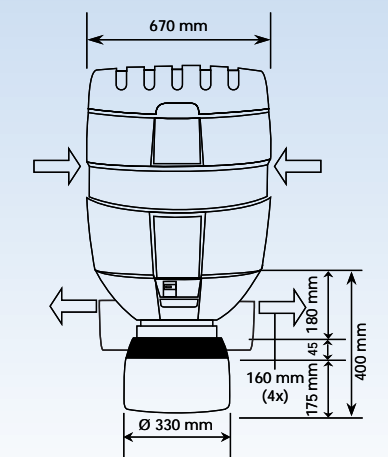

The Statiflex 400-MS is based on the fully automatic RotaPulse® concept. The cleaning of the filter segment by segment with compressed air results in a constant high airflow. RotaPulse® operates with compressed air and is equipped accordingly with an external connection as standard. A control voltage of 24 Volt is required to drive the pulse/cleaning mechanism. The Statiflex 400-MS is designed for intensive welding operations, whereby dry welding fumes are released. It is suitable for one extraction arm in combination with a fan SF 2400 or fan SF 4200.

ADVANTAGE

- ✓ RotaPulse® automatic filter cleaning
- ✓ Cartridge filter with ExtraCoat® treatment
- ✓ Filter surface area 30 m²
- ✓ Filter efficiency up to 99.8%
- ✓ Max. noise level 69 dB(A)
- ✓ Aluminium spark arrester
- ✓ Compressed air connection 4-5 bar
- ✓ Suitable for one extraction arm in combination with a fan SF 2400/SF 4200
- ✓ Weight 85 kg
- ✓ Control voltage 24 V

STATIFLEX 300-E ELECTROSTATIC FILTER

The Statiflex 300-E is most suited to the extraction of welding fumes originating from oil treated steel. It can be supplied in two capacities: The Statiflex 300-E-1 is suitable for a maximum of two workplaces if the fumes are discharged to the outside. The Statiflex 300-E-2 can handle a maximum of five workplaces. If recirculation is used, these numbers are respectively one and three. Greater capacities can be achieved by combining separate Statiflex 300-E units. By combining various types of prefilters and final filters, the most suitable extraction can be achieved for each machining process.

ADVANTAGE

- ✓ Electrostatic filter system, easy clean
- ✓ Collector surface area:
 - Statiflex 300-E-1: 14.2 m²
 - Statiflex 300-E-2: 28.4 m²
- ✓ Filter efficiency up to 99%
- ✓ Aluminium spark arrester
- ✓ Power consumption:
 - Statiflex 300-E-1: 30 W
 - Statiflex 300-E-2: 50 W
- ✓ Maximum capacity with external discharge
 - Statiflex 300-E-1: 2500 m³/h
 - Statiflex 300-E-2: 5000 m³/h
- Maximum capacity with recirculation
 - Statiflex 300-E-1: 1000 m³/h
 - Statiflex 300-E-2: 3000 m³/h
- ✓ High voltage indicator light
- ✓ Fitted with an oil collector as standard
- ✓ Can optionally be fitted with an oil drain tap and various types of prefilters and final filters
- ✓ Weight
 - Statiflex 300-E-1: 60 kg
 - Statiflex 300-E-2: 100 kg

Dimensions Statiflex 300-M

