

MAGNUM[®] 300 and 400 GMA GUN & CABLE ASSEMBLIES

IM381-D

October, 2005

Models K470 K1802-1
K471 K2286-1
K541

K574 is now located in IM646

Safety Depends on You

Lincoln arc welding and cutting equipment is designed and built with safety in mind. However, your overall safety can be increased by proper installation ... and thoughtful operation on your part. DO NOT INSTALL, OPERATE OR REPAIR THIS EQUIPMENT WITHOUT READING THIS MANUAL AND THE SAFETY PRECAUTIONS CONTAINED THROUGHOUT. And, most importantly, think before you act and be careful.

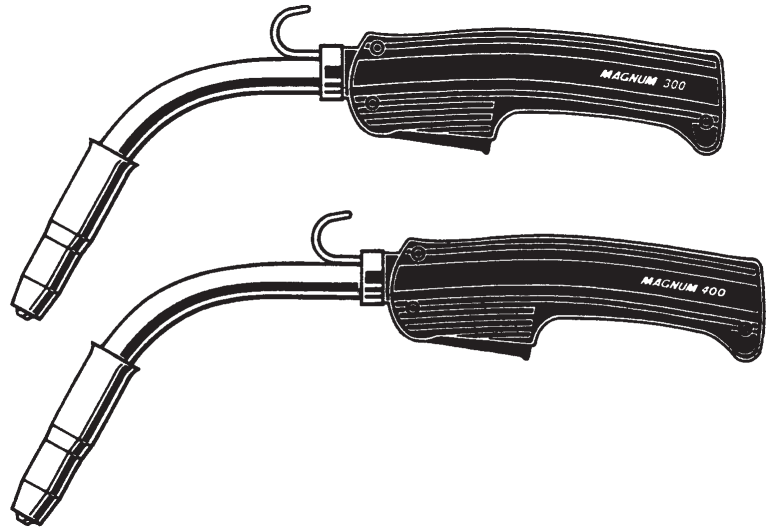

OPERATOR'S MANUAL



LINCOLN[®]
ELECTRIC

Copyright © 2005 Lincoln Global Inc.

- World's Leader in Welding and Cutting Products •
- Sales and Service through Subsidiaries and Distributors Worldwide •

Cleveland, Ohio 44117-1199 U.S.A. TEL: 216.481.8100 FAX: 216.486.1751 WEB SITE: www.lincolnelectric.com

⚠ WARNING

⚠ CALIFORNIA PROPOSITION 65 WARNINGS ⚠

Diesel engine exhaust and some of its constituents are known to the State of California to cause cancer, birth defects, and other reproductive harm.

The Above For Diesel Engines

The engine exhaust from this product contains chemicals known to the State of California to cause cancer, birth defects, or other reproductive harm.

The Above For Gasoline Engines

ARC WELDING CAN BE HAZARDOUS. PROTECT YOURSELF AND OTHERS FROM POSSIBLE SERIOUS INJURY OR DEATH. KEEP CHILDREN AWAY. PACEMAKER WEARERS SHOULD CONSULT WITH THEIR DOCTOR BEFORE OPERATING.

Read and understand the following safety highlights. For additional safety information, it is strongly recommended that you purchase a copy of "Safety in Welding & Cutting - ANSI Standard Z49.1" from the American Welding Society, P.O. Box 351040, Miami, Florida 33135 or CSA Standard W117.2-1974. A Free copy of "Arc Welding Safety" booklet E205 is available from the Lincoln Electric Company, 22801 St. Clair Avenue, Cleveland, Ohio 44117-1199.

BE SURE THAT ALL INSTALLATION, OPERATION, MAINTENANCE AND REPAIR PROCEDURES ARE PERFORMED ONLY BY QUALIFIED INDIVIDUALS.



FOR ENGINE powered equipment.

1.a. Turn the engine off before troubleshooting and maintenance work unless the maintenance work requires it to be running.



1.b. Operate engines in open, well-ventilated areas or vent the engine exhaust fumes outdoors.



1.c. Do not add the fuel near an open flame welding arc or when the engine is running. Stop the engine and allow it to cool before refueling to prevent spilled fuel from vaporizing on contact with hot engine parts and igniting. Do not spill fuel when filling tank. If fuel is spilled, wipe it up and do not start engine until fumes have been eliminated.

1.d. Keep all equipment safety guards, covers and devices in position and in good repair. Keep hands, hair, clothing and tools away from V-belts, gears, fans and all other moving parts when starting, operating or repairing equipment.

1.e. In some cases it may be necessary to remove safety guards to perform required maintenance. Remove guards only when necessary and replace them when the maintenance requiring their removal is complete. Always use the greatest care when working near moving parts.



1.f. Do not put your hands near the engine fan. Do not attempt to override the governor or idler by pushing on the throttle control rods while the engine is running.

1.g. To prevent accidentally starting gasoline engines while turning the engine or welding generator during maintenance work, disconnect the spark plug wires, distributor cap or magneto wire as appropriate.



1.h. To avoid scalding, do not remove the radiator pressure cap when the engine is hot.



ELECTRIC AND MAGNETIC FIELDS may be dangerous

2.a. Electric current flowing through any conductor causes localized Electric and Magnetic Fields (EMF). Welding current creates EMF fields around welding cables and welding machines.

2.b. EMF fields may interfere with some pacemakers, and welders having a pacemaker should consult their physician before welding.

2.c. Exposure to EMF fields in welding may have other health effects which are now not known.

2.d. All welders should use the following procedures in order to minimize exposure to EMF fields from the welding circuit:

2.d.1. Route the electrode and work cables together - Secure them with tape when possible.

2.d.2. Never coil the electrode lead around your body.

2.d.3. Do not place your body between the electrode and work cables. If the electrode cable is on your right side, the work cable should also be on your right side.

2.d.4. Connect the work cable to the workpiece as close as possible to the area being welded.

2.d.5. Do not work next to welding power source.

Mar '95



ELECTRIC SHOCK can kill.

3.a. The electrode and work (or ground) circuits are electrically "hot" when the welder is on. Do not touch these "hot" parts with your bare skin or wet clothing. Wear dry, hole-free gloves to insulate hands.

3.b. Insulate yourself from work and ground using dry insulation. Make certain the insulation is large enough to cover your full area of physical contact with work and ground.

In addition to the normal safety precautions, if welding must be performed under electrically hazardous conditions (in damp locations or while wearing wet clothing; on metal structures such as floors, gratings or scaffolds; when in cramped positions such as sitting, kneeling or lying, if there is a high risk of unavoidable or accidental contact with the workpiece or ground) use the following equipment:

- Semiautomatic DC Constant Voltage (Wire) Welder.
- DC Manual (Stick) Welder.
- AC Welder with Reduced Voltage Control.

3.c. In semiautomatic or automatic wire welding, the electrode, electrode reel, welding head, nozzle or semiautomatic welding gun are also electrically "hot".

3.d. Always be sure the work cable makes a good electrical connection with the metal being welded. The connection should be as close as possible to the area being welded.

3.e. Ground the work or metal to be welded to a good electrical (earth) ground.

3.f. Maintain the electrode holder, work clamp, welding cable and welding machine in good, safe operating condition. Replace damaged insulation.

3.g. Never dip the electrode in water for cooling.

3.h. Never simultaneously touch electrically "hot" parts of electrode holders connected to two welders because voltage between the two can be the total of the open circuit voltage of both welders.

3.i. When working above floor level, use a safety belt to protect yourself from a fall should you get a shock.

3.j. Also see Items 6.c. and 8.



ARC RAYS can burn.

4.a. Use a shield with the proper filter and cover plates to protect your eyes from sparks and the rays of the arc when welding or observing open arc welding. Headshield and filter lens should conform to ANSI Z87.1 standards.

4.b. Use suitable clothing made from durable flame-resistant material to protect your skin and that of your helpers from the arc rays.

4.c. Protect other nearby personnel with suitable, non-flammable screening and/or warn them not to watch the arc nor expose themselves to the arc rays or to hot spatter or metal.



FUMES AND GASES can be dangerous.

5.a. Welding may produce fumes and gases hazardous to health. Avoid breathing these fumes and gases. When welding, keep your head out of the fume. Use enough ventilation and/or exhaust at the arc to keep fumes and gases away from the breathing zone. **When welding with electrodes which require special ventilation such as stainless or hard facing (see instructions on container or MSDS) or on lead or cadmium plated steel and other metals or coatings which produce highly toxic fumes, keep exposure as low as possible and below Threshold Limit Values (TLV) using local exhaust or mechanical ventilation. In confined spaces or in some circumstances, outdoors, a respirator may be required. Additional precautions are also required when welding on galvanized steel.**

5.b. Do not weld in locations near chlorinated hydrocarbon vapors coming from degreasing, cleaning or spraying operations. The heat and rays of the arc can react with solvent vapors to form phosgene, a highly toxic gas, and other irritating products.

5.c. Shielding gases used for arc welding can displace air and cause injury or death. Always use enough ventilation, especially in confined areas, to insure breathing air is safe.

5.d. Read and understand the manufacturer's instructions for this equipment and the consumables to be used, including the material safety data sheet (MSDS) and follow your employer's safety practices. MSDS forms are available from your welding distributor or from the manufacturer.

5.e. Also see item 1.b.

Mar '95

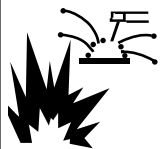

WELDING SPARKS can cause fire or explosion.

6.a. Remove fire hazards from the welding area.

If this is not possible, cover them to prevent the welding sparks from starting a fire.

Remember that welding sparks and hot materials from welding can easily go through small cracks and openings to adjacent areas. Avoid welding near hydraulic lines. Have a fire extinguisher readily available.

6.b. Where compressed gases are to be used at the job site, special precautions should be used to prevent hazardous situations. Refer to "Safety in Welding and Cutting" (ANSI Standard Z49.1) and the operating information for the equipment being used.

6.c. When not welding, make certain no part of the electrode circuit is touching the work or ground. Accidental contact can cause overheating and create a fire hazard.

6.d. Do not heat, cut or weld tanks, drums or containers until the proper steps have been taken to insure that such procedures will not cause flammable or toxic vapors from substances inside. They can cause an explosion even though they have been "cleaned". For information, purchase "Recommended Safe Practices for the Preparation for Welding and Cutting of Containers and Piping That Have Held Hazardous Substances", AWS F4.1 from the American Welding Society (see address above).

6.e. Vent hollow castings or containers before heating, cutting or welding. They may explode.

6.f. Sparks and spatter are thrown from the welding arc. Wear oil free protective garments such as leather gloves, heavy shirt, cuffless trousers, high shoes and a cap over your hair. Wear ear plugs when welding out of position or in confined places. Always wear safety glasses with side shields when in a welding area.

6.g. Connect the work cable to the work as close to the welding area as practical. Work cables connected to the building framework or other locations away from the welding area increase the possibility of the welding current passing through lifting chains, crane cables or other alternate circuits. This can create fire hazards or overheat lifting chains or cables until they fail.

6.h. Also see item 1.c.



CYLINDER may explode if damaged.

7.a. Use only compressed gas cylinders containing the correct shielding gas for the process used and properly operating regulators designed for the gas and pressure used. All hoses, fittings, etc. should be suitable for the application and maintained in good condition.

7.b. Always keep cylinders in an upright position securely chained to an undercarriage or fixed support.

7.c. Cylinders should be located:

- Away from areas where they may be struck or subjected to physical damage.
- A safe distance from arc welding or cutting operations and any other source of heat, sparks, or flame.

7.d. Never allow the electrode, electrode holder or any other electrically "hot" parts to touch a cylinder.

7.e. Keep your head and face away from the cylinder valve outlet when opening the cylinder valve.

7.f. Valve protection caps should always be in place and hand tight except when the cylinder is in use or connected for use.

7.g. Read and follow the instructions on compressed gas cylinders, associated equipment, and CGA publication P-1, "Precautions for Safe Handling of Compressed Gases in Cylinders," available from the Compressed Gas Association 1235 Jefferson Davis Highway, Arlington, VA 22202.



FOR ELECTRICALLY powered equipment.

8.a. Turn off input power using the disconnect switch at the fuse box before working on the equipment.

8.b. Install equipment in accordance with the U.S. National Electrical Code, all local codes and the manufacturer's recommendations.

8.c. Ground the equipment in accordance with the U.S. National Electrical Code and the manufacturer's recommendations.

Mar '95

PRÉCAUTIONS DE SÛRETÉ

Pour votre propre protection lire et observer toutes les instructions et les précautions de sûreté spécifiques qui paraissent dans ce manuel aussi bien que les précautions de sûreté générales suivantes:

Sûreté Pour Soudage A L'Arc

1. Protégez-vous contre la secousse électrique:
 - a. Les circuits à l'électrode et à la pièce sont sous tension quand la machine à souder est en marche. Eviter toujours tout contact entre les parties sous tension et la peau nue ou les vêtements mouillés. Porter des gants secs et sans trous pour isoler les mains.
 - b. Faire très attention de bien s'isoler de la masse quand on soude dans des endroits humides, ou sur un plancher métallique ou des grilles métalliques, principalement dans les positions assis ou couché pour lesquelles une grande partie du corps peut être en contact avec la masse.
 - c. Maintenir le porte-électrode, la pince de masse, le câble de soudage et la machine à souder en bon et sûr état de fonctionnement.
 - d. Ne jamais plonger le porte-électrode dans l'eau pour le refroidir.
 - e. Ne jamais toucher simultanément les parties sous tension des porte-électrodes connectés à deux machines à souder parce que la tension entre les deux pinces peut être le total de la tension à vide des deux machines.
 - f. Si on utilise la machine à souder comme une source de courant pour soudage semi-automatique, ces précautions pour le porte-électrode s'appliquent aussi au pistolet de soudage.
2. Dans le cas de travail au dessus du niveau du sol, se protéger contre les chutes dans le cas où on reçoit un choc. Ne jamais enrouler le câble-électrode autour de n'importe quelle partie du corps.
3. Un coup d'arc peut être plus sévère qu'un coup de soleil, donc:
 - a. Utiliser un bon masque avec un verre filtrant approprié ainsi qu'un verre blanc afin de se protéger les yeux du rayonnement de l'arc et des projections quand on soude ou quand on regarde l'arc.
 - b. Porter des vêtements convenables afin de protéger la peau de soudeur et des aides contre le rayonnement de l'arc.
 - c. Protéger l'autre personnel travaillant à proximité au soudage à l'aide d'écrans appropriés et non-inflammables.
4. Des gouttes de laitier en fusion sont émises de l'arc de soudage. Se protéger avec des vêtements de protection libres de l'huile, tels que les gants en cuir, chemise épaisse, pantalons sans revers, et chaussures montantes.

5. Toujours porter des lunettes de sécurité dans la zone de soudage. Utiliser des lunettes avec écrans latéraux dans les zones où l'on pique le laitier.
6. Eloigner les matériaux inflammables ou les recouvrir afin de prévenir tout risque d'incendie dû aux étincelles.
7. Quand on ne soude pas, poser la pince à un endroit isolé de la masse. Un court-circuit accidentel peut provoquer un échauffement et un risque d'incendie.
8. S'assurer que la masse est connectée le plus près possible de la zone de travail qu'il est pratique de le faire. Si on place la masse sur la charpente de la construction ou d'autres endroits éloignés de la zone de travail, on augmente le risque de voir passer le courant de soudage par les chaînes de levage, câbles de grue, ou autres circuits. Cela peut provoquer des risques d'incendie ou d'échauffement des chaînes et des câbles jusqu'à ce qu'ils se rompent.
9. Assurer une ventilation suffisante dans la zone de soudage. Ceci est particulièrement important pour le soudage de tôles galvanisées plombées, ou cadmiées ou tout autre métal qui produit des fumées toxiques.
10. Ne pas souder en présence de vapeurs de chlore provenant d'opérations de dégraissage, nettoyage ou pistologie. La chaleur ou les rayons de l'arc peuvent réagir avec les vapeurs du solvant pour produire du phosgène (gas fortement toxique) ou autres produits irritants.
11. Pour obtenir de plus amples renseignements sur la sûreté, voir le code "Code for safety in welding and cutting" CSA Standard W 117.2-1974.

PRÉCAUTIONS DE SÛRETÉ POUR LES MACHINES À SOUDER À TRANSFORMATEUR ET À REDRESSEUR

1. Relier à la terre le châssis du poste conformément au code de l'électricité et aux recommandations du fabricant. Le dispositif de montage ou la pièce à souder doit être branché à une bonne mise à la terre.
2. Autant que possible, l'installation et l'entretien du poste seront effectués par un électricien qualifié.
3. Avant de faire des travaux à l'intérieur de poste, la débrancher à l'interrupteur à la boîte de fusibles.
4. Garder tous les couvercles et dispositifs de sûreté à leur place.

Thank You

for selecting a **QUALITY** product by Lincoln Electric. We want you to take pride in operating this Lincoln Electric Company product ••• as much pride as we have in bringing this product to you!

Please Examine Carton and Equipment For Damage Immediately

When this equipment is shipped, title passes to the purchaser upon receipt by the carrier. Consequently, Claims for material damaged in shipment must be made by the purchaser against the transportation company at the time the shipment is received.

Please record your equipment identification information below for future reference. This information can be found on your machine nameplate.

Product _____

Model Number _____

Code Number or Date Code _____

Serial Number _____

Date Purchased _____

Where Purchased _____

Whenever you request replacement parts or information on this equipment, always supply the information you have recorded above. The code number is especially important when identifying the correct replacement parts.

On-Line Product Registration

- Register your machine with Lincoln Electric either via fax or over the Internet.

- For faxing: Complete the form on the back of the warranty statement included in the literature packet accompanying this machine and fax the form per the instructions printed on it.
- For On-Line Registration: Go to our **WEB SITE at www.lincolnelectric.com**. Choose "Quick Links" and then "Product Registration". Please complete the form and submit your registration.

Read this Operators Manual completely before attempting to use this equipment. Save this manual and keep it handy for quick reference. Pay particular attention to the safety instructions we have provided for your protection. The level of seriousness to be applied to each is explained below:

⚠ WARNING

This statement appears where the information **must** be followed **exactly** to avoid **serious personal injury** or **loss of life**.

⚠ CAUTION

This statement appears where the information **must** be followed to avoid **minor personal injury** or **damage to this equipment**.

TABLE OF CONTENTS

	Page
General Description	Section A
<hr/>	
Installation	Section B
Connector Kit Installation to Gun Cable	B-1
K466-1 &-8 Installation	B-1
K466-2 Installation	B-1
K466-3 Installation	B-1
K466-4 Installation	B-1
K466-5 Installation	B-2
K466-6, 7, 9 & 10 Installation	B-2
Liner Installation	B-2
Contact Tip and Gas Nozzle Installation	B-3
Connection to Feeder	B-3
Connection to Lincoln Feeders	B-3
Connection to Tweco Adapted Feeders	B-3
Connection to Miller Feeders	B-3
Connection to Hobart Feeders	B-4
Connection to L-Tec Adapted Feeders	B-4
Connection to Lincoln Wirematic, Hobart Series 2000 or SP100T Feeders	B-4
Connection to 10 Series Feeders	B-5
<hr/>	
Operation	Section C
Electrodes and Equipment	C-1
Making a Weld	C-1
Avoiding Wire Feeding Problems	C-1
<hr/>	
Maintenance	Section D
Removal, Installation and Trimming Instructions for Magnum Liners	D-1
Gun Tubes and Nozzles	D-1
Gun Cables	D-1
Cable Cleaning	D-1
Cable Repair (K470, K471 & K541 Models)	D-1
Gun Tube End Repair	D-1
Wire Feeder End Repair	D-3
Thread Sizes for 300 and 400 Amp Consumables	D-5
<hr/>	
Troubleshooting	Section E
<hr/>	
Parts Lists	P202-C
<hr/>	

GENERAL DESCRIPTION

The Magnum™ 300 amp and 400 amp GMA gun and cable assemblies have been designed to meet NEMA specification EW3 for welding with steel electrode using the GMAW (gas metal arc welding) and gas-shielded FCAW (flux-cored arc welding) processes.

Most models of Magnum 300 and 400 guns are not factory equipped with a feeder end connector, except K1802-1 and K2286-1, (they have a factory installed feeder end connector). With the K466-1 Magnum Connector Kit, they can be used with any Lincoln LN-7 or LN-25 semiautomatic wire feeder. The K466-1 should also be used with the LN-8 or LN-9 when feeding .052 and smaller electrodes. An optional K481 Magnum Fast-Connect Gas Tube Kit is available to provide tool-less gas tube connection to Lincoln wire feeders. Non-GMA model wire feeders require an optional gas solenoid valve.

The 300 and 400 guns can also be used with any wire feeder equipped with a Tweco® #1, 2, 3, 350 or 4 wire feed adapter kit by using the K466-2 Magnum Connector Kit.

With the K466-3 or K466-4 Magnum connector kits, it is possible to connect Magnum 300 and 400 guns directly to a variety of Miller and Hobart wire feeders, respectively.

The K466-5 connector kit allows connection of Magnum 300 and 400 guns to an L Tec feeder connector assembly. L-Tec feeders require a feeder connector assembly (similar to a Tweco® adapter) in order to connect to a gun and cable. The K466-5 contains a brass connector to permit Magnum guns to be connected to this feeder connector assembly.

The K466-6 connector kit allows connection of Magnum 300 and 400 guns to a Lincoln Wirematic.

The K466-7 connector kit allows connection of Magnum 300 and 400 guns to Hobart Series 2000 Wire Feeders.

The K466-8 connector kit allows connection of Magnum 300 and 400 guns to an LN8 or LN9 when 1/16 and larger electrode is used.

The K466-9 connector kit allows connection of K497 to SP100T and related wire feeders.

The K466-10 connector kit allows connection of Magnum 300 and 400 guns to a 10 Series wire feeder.

For best results when welding mild and alloy steels, it is recommended that L-50 or L-56 Lincoln solid wire electrodes be used for the GMAW process and OS70 or OS71 Lincoln Outershield cored electrodes for the gas-shielded FCAW process.

WARNING



- Do not touch electrically live parts such as output terminals or internal wiring

MAGNUM 300 (300 amperes) AT 60% DUTY CYCLE WITH CO ₂ GAS*								
Description Product Number	Gun Cable Length (m)	Wire Size in. (mm)	Contact Tips Standard Duty	Gas Diffuser Assembly	Gas Nozzle	Insulator	Cable Liner	Gun Tube 60°
K470-1	10 ft. (3.0)	.035 (0.9) .045 (1.2)	KP2020-1B1 -2B1	KP2024-1	KP1932-1	KP2023-1	KP1933-1	KP1928-2
K470-7	12 ft. (3.0)	.035 (0.9) .045 (1.2)	KP2020-1B1 -2B1	KP2024-1	KP1932-1	KP2023-1	KP1933-1	KP1928-2
K470-2 / K1802-1 ^Δ	15 ft. (4.5)	.035 (0.9) .045 (1.2)	KP2020-1B1 -2B1	KP2024-1	KP1932-1	KP2023-1	KP1933-1	KP1928-2
K470-3	10 ft. (3.0)	.052 (1.3) 1/16 (1.6)	KP2020-3B1 -4B1	KP2024-1	KP1932-1	KP2023-1	KP1933-2	KP1928-2
K470-8	12 ft. (3.6)	.052 (1.3) 1/16 (1.6)	KP2020-3B1 -4B1	KP2024-1	KP1932-1	KP2023-1	KP1933-2	KP1928-2
K470-4	15 ft. (4.5)	.052 (1.3) 1/16 (1.6)	KP2020-3B1 -4B1	KP2024-1	KP1932-1	KP2023-1	KP1933-2	KP1928-2
K470-5	10 ft. (3.0)	1/16 (1.6) 5/64 (2.0)	KP2020-4B1 -5B1	KP2024-1	KP1932-1	KP2023-1	KP1933-3	KP1928-2
K470-9	12 ft. (3.6)	1/16 (1.6) 5/64 (2.0)	KP2020-4B1 -5B1	KP2024-1	KP1932-1	KP2023-1	KP1933-3	KP1928-2
K470-6	15 ft. (4.5)	1/16 (1.6) 5/64 (2.0)	KP2020-4B1 -5B1	KP2024-1	KP1932-1	KP2023-1	KP1933-3	KP1928-2

* May also be used with other gases at reduced rating (up to 50%)

^ΔK1802-1 Magnum 300 Gun has a factory installed feeder end connector.

MAGNUM 400 (400 amperes) AT 60% DUTY CYCLE WITH CO ₂ GAS*								
Description Product Number	Gun Cable Length (m)	Wire Size in. (mm)	Contact Tips Standard Duty	Gas Diffuser Assembly	Gas Nozzle	Insulator	Cable Liner	Gun Tube 60°
K471-1	10 ft. (3.0)	.035 (0.9) .045 (1.2)	KP2020-1B1 -2B1	KP2024-1	KP1932-1	KP2023-1	KP1933-1	KP1928-2
K471-7	12 ft. (3.6)	.035 (0.9) .045 (1.2)	KP2020-1B1 -2B1	KP2024-1	KP1932-1	KP2023-1	KP1933-1	KP1928-2
K471-2/ K2286-1 ^Δ	15 ft. (4.5)	.035 (0.9) .045 (1.2)	KP2020-1B1 -2B1	KP2024-1	KP1932-1	KP2023-1	KP1933-1	KP1928-2
K471-10	20 ft. (6.1)	.035 (0.9) .045 (1.2)	KP2020-1B1 -2B1	KP2024-1	KP1932-1	KP2023-1	KP1933-1	KP1928-2
K471-13	25 ft. (7.6)	.035 (0.9) .045 (1.2)	KP2020-1B1 -2B1	KP2024-1	KP1932-1	KP2023-1	KP1933-1	KP1928-2
K471-3	10 ft. (3.0)	.052 (1.3) 1/16 (1.6)	KP2020-3B1 -4B1	KP2024-1	KP1932-1	KP2023-1	KP1933-2	KP1928-2
K471-8	12 ft. (3.6)	.052 (1.3) 1/16 (1.6)	KP2020-3B1 -4B1	KP2024-1	KP1932-1	KP2023-1	KP1933-2	KP1928-2
K471-4	15 ft. (4.5)	.052 (1.3) 1/16 (1.6)	KP2020-3B1 -4B1	KP2024-1	KP1932-1	KP2023-1	KP1933-2	KP1928-2
K471-11	20 ft. (6.1)	.052 (1.3) 1/16 (1.6)	KP2020-3B1 -4B1	KP2024-1	KP1932-1	KP2023-1	KP1933-2	KP1928-2
K471-14	25 ft. (7.6)	.052 (1.3) 1/16 (1.6)	KP2020-3B1 -4B1	KP2024-1	KP1932-1	KP2023-1	KP1933-2	KP1928-2
K471-5	10 ft. (3.0)	1/16 (1.6) 5/64 (2.0)	KP2020-4B1 -5B1	KP2024-1	KP1932-1	KP2023-1	KP1933-3	KP1928-2
K471-9	12 ft. (3.6)	1/16 (1.6) 5/64 (2.0)	KP2020-4B1 -5B1	KP2024-1	KP2023-1	KP2023-1	KP1933-3	KP1928-2
K471-6	15 ft. (4.5)	1/16 (1.6) 5/64 (2.0)	KP2020-4B1 -5B1	KP2024-1	KP2023-1	KP2023-1	KP1933-3	KP1928-2
K471-12	20 ft. (6.1)	1/16 (1.6) 5/64 (2.0)	KP2020-4B1 -5B1	KP2024-1	KP1932-1	KP2023-1	KP1933-3	KP1928-2
K471-15	25 ft. (7.6)	1/16 (1.6) 5/64 (2.0)	KP2020-4B1 -5B1	KP2024-1	KP1932-1	KP2023-1	KP1933-3	KP1928-2

* May also be used with other gases at reduced rating (up to 50%)

^ΔK2286-1 Magnum 400 Gun has a factory installed feeder end connector.

MAGNUM 400 COMPLETE ASSEMBLY WITH TWECO CONNECTOR (400 amperes) AT 60% DUTY CYCLE WITH CO ₂ GAS*								
Description Product Number	Gun Cable Length (m)	Wire Size in. (mm)	Contact Tips Standard Duty	Gas Diffuser Assembly	Gas Nozzle	Insulator	Cable Liner	Gun Tube 60°
K471-21	15 ft. (4.5)	.035 (0.9) .045 (1.2)	KP2020-1B1 -2B1	KP2024-1	KP1932-1	KP2023-1	KP1933-1	KP1928-2
K471-22	15 ft. (4.5)	.052 (1.3) 1/16 (1.6)	KP2020-3B1 -4B1	KP2024-1	KP1932-1	KP2023-1	KP1933-2	KP1928-2
K471-23	15 ft. (4.5)	1/16 (1.6) 5/64 (2.0)	KP2020-4B1 -5B1	KP2024-1	KP1932-1	KP2023-1	KP1933-3	KP1928-2

* May also be used with other gases at reduced rating (up to 50%)

MAGNUM 300 & 400



MAGNUM 400 SHORT NECK (400 amperes at reduced duty cycle) 40% WITH CO₂ GAS*								
Description Product Number	Gun Cable Length (m)	Wire Size in. (mm)	Contact Tips Standard Duty	Gas Diffuser Assembly	Gas Nozzle	Insulator	Cable Liner	Gun Tube 60°
K541-1	10 ft. (3.0)	.035 (0.9) .045 (1.2)	KP2020-1B1 -2B1	KP2024-1	KP1932-1	KP2023-1	KP1933-1	KP1928-2
K541-2	12 ft. (3.6)	.035 (0.9) .045 (1.2)	KP2020-1B1 -2B1	KP2024-1	KP1932-1	KP2023-1	KP1933-1	KP1928-2
K541-3	15 ft. (4.5)	.035 (0.9) .045 (1.2)	KP2020-1B1 -2B1	KP2024-1	KP1932-1	KP2023-1	KP1933-1	KP1928-2

* May also be used with other gases at reduced rating (up to 30%)

MAGNUM 400 SHORT NECK COMPLETE ASSEMBLY WITH FEEDER CONNECTOR (400 amperes) @ 40% WITH CO₂ GAS *								
Description Product Number	Gun Cable Length (m)	Wire Size in. (mm)	Contact Tips Heavy Duty	Gas Diffuser Assembly	Gas Nozzle	Cable Liner	Gun Tube 60°	Feeder** Type
K541-21	15 ft. (4.5)	.035 (0.9) .045 (1.2)	KP2021-1B1 -2B1	KP2024-1	KP1930 -2	KP1933-1	KP1928-2	Miller K466-3
K541-22	15 ft. (4.5)	.052 (1.3) 1/16 (1.6)	KP2021-3B1 -4B1	KP2024-1	KP1930 -2	KP1933-2	KP1928-2	Miller K466-3
K541-23	15 ft. (4.5)	.035 (0.9) .045 (1.2)	KP2021-1B1 -2B1	KP2024-1	KP1930 -2	KP1933-1	KP1928-2	Lincoln K466-1
K541-24	15 ft. (4.5)	.052 (1.3) 1/16 (1.6)	KP2021-3B1 -4B1	KP2024-1	KP1930 -2	KP1933-2	KP1928-2	Lincoln K466-8
K541-25	15 ft. (4.5)	.035 (0.9) .045 (1.2)	KP2021-1B1 -2B1	KP2024-1	KP1930 -2	KP1933-1	KP1928-2	Tweco K466-2
K541-26	15 ft. (4.5)	.052 (1.3) 1/16 (1.6)	KP2021-3B1 -4B1	KP2024-1	KP1930 -2	KP1933-2	KP1928-2	Tweco K466-2

* May also be used with other gases at reduced rating (up to 30%)

** Feeder Kits installed on the gun at the factory.

Read this entire installation section before you start installation.

SAFETY PRECAUTIONS

WARNING



ELECTRIC SHOCK can kill.

- Do not touch electrically live parts such as output terminals or internal wiring.
- Insulate yourself from the work and ground.
- Always wear dry insulating gloves.

Only qualified personnel should install, use or service this equipment

CONNECTOR KIT INSTALLATION TO GUN CABLE

Most models of Magnum 300 and Magnum 400 gun cables, except K1802-1 and K2286-1, are shipped as generic assemblies and must be assembled with a K466 connector kit (See REPLACEMENT PARTS section Chart E for proper kit). The Magnum 400 Gun K2286-1 has a factory installed feeder end connector.

K466-1& -8 INSTALLATION (For Lincoln Feeders)

- a. Remove brass cable connector and insulation tube (see Figure 1) from the K466-1 kit. Slide the insulation tube onto the connector from the threaded end and screw it onto the feeder end of the gun cable. Tighten the connection with the wrench provided.
- b. Remove the molded gas plug fitting on the side of the feeder end handle and replace it with the barbed brass fitting provided in the kit. The included wrench will fit both the gas plug and barbed fitting.
- c. Attach the round connector of the gun control cable provided to the trigger connector on the front of the Lincoln feeder. (**NOTE:** Both the plug and socket are keyed and must be properly oriented.)
- d. Place one tubing clamp onto each end of the flexible tubing provided, approximately 2" (51 mm) in from each end. Slide one end of the tubing onto the barbed connector on the feeder end cable handle (step b) and move the clamp down near the end of the tube to ensure a good gas seal.

NOTE: An optional K481 Magnum Fast-Connect Gas Tube Kit is available to provide tool-less gas tube connection to Lincoln wire feeders. Install per the instructions sent with the kit.

K466-2 INSTALLATION (For Tweco Adapted Feeders)

- a. Remove brass cable connector (see Figure 1) from the K466-2 kit and screw it onto the feeder end of the gun cable. Tighten the connection with the wrench provided.
- b. Check that the molded gas plug fitting is sealing the gas fitting hole in the side of the feeder end handle.

K466-3 INSTALLATION (For Miller Feeders)

- a. Remove brass cable connector (see Figure 1) from the K466-3 kit and screw it onto the feeder end of the gun cable. Tighten the connection with the wrench provided.
- b. Check that the molded gas plug fitting is sealing the gas fitting hole in the side of the feeder end handle.
- c. Attach the round connector of the gun control cable provided to the trigger connector on the front of the Miller feeder.

K466-4 INSTALLATION (For Hobart Feeders)

- a. Remove brass cable connector (see Figure 1) from the K466-4 kit and screw it onto the feeder end of the gun cable. Tighten the connection with the wrench provided.
- b. Remove the molded gas plug fitting on the side of the feeder end handle and replace it with the barbed brass fitting provided in the kit. The included wrench will fit both the gas plug and barbed fitting.
- c. Attach the phone plug connector of the gun control cable provided to the trigger connector on the front of the Hobart feeder.
- d. Place one tubing clamp onto each end of the flexible tubing provided, approximately 2" (51 mm) in from each end. Slide one end of the tubing onto the barbed connector on the feeder end cable handle (step b) and move the clamp down near the end of the tube to assure a good gas seal.

K466-5 INSTALLATION (For L-Tec Feeders)

- a. Remove brass cable connector (see Figure 1) from the K466-5 kit and screw it onto the feeder end of the gun cable. Tighten the connection with the wrench provided.
- b. Check that the molded gas plug fitting is sealing the gas fitting hole in the side of the feeder end handle.

- c. For L-Tec machines that require trigger lead connections to be made at a terminal strip located within the machine (L-Tec 225), a gun control cable with forked terminals is provided. Connect the terminated leads to the terminal strip. For a machine that requires a twist-lock gun control cable connection, continue to use the L-Tec gun control cable provided with the L-Tec wire feeder connector assembly. Connect the twist-lock plug to the proper receptacle on the machine.

K466-6, K466-7, K466-9 and K466-10 Installation (Wirematic, Hobart Series 2000 Feeders, SP100T Type and Lincoln 10 Series Feeders)

- Remove brass cable connector (see Figure 1) from the connector kit and screw it onto the feeder end of the gun cable. Tighten the connection with the wrench provided.
- Check that the molded gas plug fitting is sealing the gas fitting hole in the side of the feeder end handle.
- Attach the gun control cable provided to the trigger connector on the front of the wire feeder.

LINER INSTALLATION AND TRIMMING INSTRUCTIONS

Installation of (KP1932, KP1936 and KP1955 series liners)

- Lay the gun and cable straight on a flat surface.
- Make sure that the set screw in the connector end is backed out so as not to damage liner or liner

bushing. Remove and save the gas nozzle, nozzle insulator, and gas diffuser from the end of the gun tube assembly.

- Insert a new untrimmed liner into the connector end of the cable. Be sure the liner bushing is stenciled appropriately for the wire size being used.

d. **NOTE: For liners KP1950-7, KP1950-8, KP1955-1 and KP1955-2**

Before fully seating the liner bushing, it will be necessary to trim the liner's inner tube flush with the liner bushing using a sharp blade. After trimming, remove any burrs from inner tube and insure that the opening is fully open.

For all K466 connector kits except K466-3 and K466-4, tighten the set screw in the cable connector.

or

For K466-3 and K466-4, screw in the connector cap provided in the kit until it seats on the face of the bushing. Then insert the appropriate piece of liner material into the connector cap and tighten the set screw. Three pieces of liner material are included in these connector kits to help guide the electrode through the connector cap. The piece with the smallest inner diameter is designed for .045" (1.2 mm) maximum diameter electrode. The next largest diameter is for 1/16" (1.6 mm) maximum diameter electrode. The largest diameter piece of liner material is for 5/64" (2.0 mm) maximum diameter electrode.

- Be sure the cable is straight and then trim the liner to the length shown in Figure 1 (a gauge is included on the wrench provided with the connection kit for gauging the cut-off length on 300 and 400 amp gun tubes). Remove any burrs from the end of the liner.

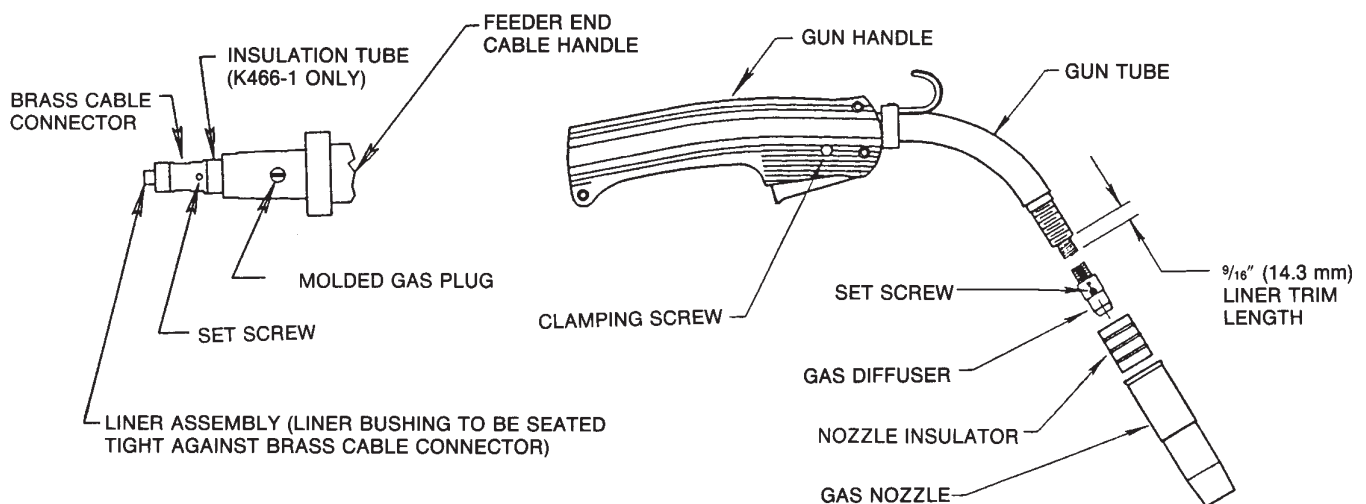

Figure 1

MAGNUM 300 & 400



- f. Screw the gas diffuser onto the end of the gun tube and tighten with the wrench provided.
- g. Tighten the set screw in the side of the gas diffuser against the cable liner using the Allen wrench provided.

⚠ CAUTION

This screw should only be gently tightened. Overtightening will split or collapse the liner and cause poor wire feeding.

- h. Replace the nozzle insulator and gas nozzle.

INSTALLATION OF M18732 SERIES LINERS FOR FEEDING ALUMINUM ELECTRODE

1. Lay the gun out straight on a flat surface and remove the gas nozzle.
 - A. For all K466 except K466-3 and K466-4 connections, back out the set screw in the connector end with a 5/64 (2.0 mm) Allen wrench.
 - B. For all K466-3 and K466-4 connections: Remove the connector cap.
 - C. Back out the set screw in the diffuser for guns that have a set screw in the diffuser.
2. Remove the liner and insert a new untrimmed liner into the connector end of the cable. Check that the coils of the spring liner can be seen through the holes in the gas diffuser.
 - A. For all K466-3 and K466-4 connections: If the liner is going to be replaced with a different size liner, loosen the set screw on the connector cap and replace the liner material with the correct size.
3. Mark the liner 3/16" (5 mm) from the end of the liner guide or connector. Pull the liner partially out and cut off the liner at the mark using a sharp knife.
4. Screw the brass liner nipple onto the liner and fully seat the liner busing into the liner guide or the connector.
 - A. For connector kits, except K466-3 and K466-4, tighten the set screw in the cable connector.
 - B. For K466-3 and K466-4, screw in the connector cap.
5. For guns with a diffuser set screw, tighten the set screw in the side of the gas diffuser against the cable liner using the Allen wrench provided.

⚠ CAUTION

This screw should only be gently tightened. Overtightening will split or collapse the liner and cause poor wire feeding.

6. Replace the nozzle insulator and gas nozzle.

CONTACT TIP AND GAS NOZZLE INSTALLATION

- a. Choose the correct size contact tip for the electrode being used (wire size is stenciled on the side of the contact tip) and screw it snugly into the gas diffuser.
- b. Be sure the nozzle insulator is fully screwed onto the gun tube and does not block the gas holes in the diffuser. (**NOTE:** Insulator is not required when using the optional fixed gas nozzles.)
- c. Slip the appropriate gas nozzle onto the nozzle insulator. Adjustable gas nozzles are available with a .62" (15.9 mm) or .50" (12.7 mm) I.D., and in both standard (flush) and recessed design. The proper nozzle should be selected based on the welding application. Different length fixed nozzles are also available to fit 300 and 400 amp gun tubes to allow either spray or short-circuiting transfer welding.

Choose the gas nozzle as appropriate for the GMAW process to be used. Typically, the contact tip end should be flush to .12" (3.1 mm) extended for the short-circuiting transfer process and .12" (3.1 mm) recessed for spray transfer. For the Outershield (FCAW) process, 1/8" (3 mm) recess is recommended.

CONNECTION TO FEEDER

CONNECTION TO LINCOLN FEEDERS

Gun cable assemblies which were assembled with a K466-1 or -8 Connection Kit will connect easily to any Lincoln LN-7, LN-8, LN-9, SP-200 or LN-25 feeder.

- a. Check that the drive roll(s) and feeder guide tubes are appropriate for the electrode size being used.
- b. Fully push the brass connector end of the gun cable into the conductor block on the outgoing side of the feeder wire drive. Secure the cable using the hand screw or set screw in the conductor block.
- c. Insert the control cable plug from the feeder trigger circuit into the mating socket on the feeder end cable handle (See K466-1 Installation Section.)
- d. Slide the free end of the flexible hose onto the barbed gas fitting on the front of the Lincoln feeder (See K466-1 or -8 Installation Section.) Move the corresponding tubing clamp down near the end of the tube to assure a good gas seal.

CONNECTION TO ADAPTED FEEDERS

Gun cable assemblies which were assembled with a K466-2 Connection Kit will connect easily to any properly adapted feeder.

- a. Check that the adapter and feeder outgoing guide, as well as the drive roll, are appropriate for the electrode size being used.
- b. Fully push the brass connector end of the gun cable into the brass adapter on the outgoing side of the feeder wire drive. Secure the cable using the hand screw or set screw in the adapter.
- c. Insert the control cable plug from the feeder trigger circuit into the mating socket on the gun cable connector handle .

CONNECTION TO MILLER FEEDERS

Gun and cable assemblies which were assembled with a K466-3 Connector Kit will connect easily to a variety of popular Miller wire feeders.

- a. Check that the gun liner, connector cap liner, drive rolls and guide tubes are appropriate for the electrode size being used.

- b. Fully push the brass connector end of the gun and cable into the connector receptacle on the outgoing side of the feeder wire drive. Tighten the hand screw to clamp down on the connector.
- c. Insert the control cable plug from the feeder trigger circuit into the mating socket on the gun cable connector handle.

CONNECTION TO HOBART FEEDERS

Gun and cable assemblies which were assembled with a K466-4 Connector Kit will connect easily to a variety of Hobart wire feeders.

- a. Check that the gun liner, connector cap liner, drive rolls and guide tubes are appropriate for the electrode size being used.
- b. Fully push the brass connector end of the gun and cable into the connector receptacle on the outgoing side of the feeder wire drive. Tighten the hand screw to clamp down on the connector.
- c. Insert the control cable plug from the feeder trigger circuit into the mating socket on the gun cable connector handle.
- d. Slide the free end of the flexible hose (mounted to the gun in K466-4 Installation Section) onto the gas fitting on the Hobart wire feeder. Move the corresponding tubing clamp down near the end of the tube to assure a good gas seal.

CONNECTION TO L-TEC ADAPTED FEEDERS

Gun and cable assemblies which were assembled with a K466-5 connection kit will connect easily to an L-Tec feeder equipped with an L-Tec feeder connector assembly. L-Tec feeders require this connector assembly (similar to a Tweco adapter) to connect with a gun and cable.

- a. Check that the adapter and feeder outgoing guide as well as the drive roll, are appropriate for the electrode size being used.
- b. Fully push the brass connector end of the gun cable into the brass adapter on the outgoing side of the feeder wire drive. Secure the cable using the hand screw, set screw, or pin.

- c. Insert the control cable plug from the feeder trigger circuit into the mating socket on the gun cable connector handle. For machines with a twist-lock trigger lead receptacle, if the L-Tec gun control cable does not easily connect with the socket, the gun control cable that came with the K466-5 kit can be used. To do this, cut off the gun control leads as close to the forked terminals as possible and skin back the leads 7/16" (11 mm). Remove the twist-lock plug from the L-Tec control cable and connect it to the K466-5 cable. Make sure the outer jacket of the connector is caught within the plug's strain relief.

CONNECTION TO LINCOLN WIREMATIC, HOBART SERIES 2000 FEEDERS, OR SP100T TYPE FEEDERS.

Gun cable assemblies which were assembled with a K466-6, K466-7 or K466-9 Connection Kit will connect easily to a feeder.

- a. Check that the adapter and feeder outgoing guide, as well as the drive roll, are appropriate for the electrode size being used.
- b. Fully push the brass connector end of the gun cable into the outgoing side of the feeder wire drive. Secure the cable using the hand screw on the wire feeder.
- c. Insert the control cable plug from the feeder trigger circuit into the mating socket on the gun cable connector handle.

CONNECTION TO LINCOLN 10 SERIES FEEDERS

Gun cable assemblies which were assembled with a K466-10 Connection Kit or K471-21 thru -23 gun and cable assemblies will connect easily to a 10 Series feeder.

- a. Check that the K1500-2 gun adapter is in place on the wire feeder. Check that the feeder guide tubes, as well as the drive roll(s), are appropriate for the electrode size being used.
- b. Fully push the brass connector end of the gun cable into the gun adapter on the outgoing side of the feeder wire drive and secure the cable using the hand screw.
- c. Insert the control cable plug from the feeder trigger circuit into the mating socket on the gun cable connector handle.

ELECTRODES AND EQUIPMENT

The Magnum 300 and Magnum 400 guns and cables have been designed for use with Lincoln L-50 and L-56, solid steel wire electrodes for the GMAW process and Lincoln Outershield cored electrodes for the gas-shielded FCAW process. Refer to the appropriate Lincoln Process and Procedure Guidelines for the electrode used for information on recommended electrical and visible stickouts.

MAKING A WELD

⚠ WARNING

Do not attempt to use this equipment until you have thoroughly read all operating and maintenance manuals supplied with your machine. They include important safety precautions, detailed engine starting, operating and maintenance instructions and parts lists.



ELECTRIC SHOCK can kill.

- Do not touch electrically live parts such as output terminals or internal wiring.
- Insulate yourself from the work and ground.
- Always wear dry insulating gloves.



FUMES AND GASES can be dangerous.

- Keep your head out of fumes.
- Use ventilation or exhaust to remove fumes from breathing zone.



WELDING SPARKS can cause fire or explosion.

- Keep flammable material away.



ARC RAYS can burn.

- Wear eye, ear and body protection.

Only qualified personnel should operate this equipment.

- Check that the welding power source is on and that the shielding gas supply is set for the proper flow rate.
- Position electrode over joint. End of the electrode should be slightly off the work.
- Lower welding helmet. Close gun trigger and begin welding. Hold the gun so the contact tip to work distance gives the correct electrical stickout as required for the procedure being used.
- To stop welding, release the gun trigger and then pull the gun away from the work after the arc goes out. Follow wire feeder instruction manual if using a trigger interlock circuit.
- If the optional interlocking trigger is installed.
 - With the trigger pulled in all the way, the trigger can be slid forward into the interlock position.
 - To release the interlock, squeeze the trigger and pull back.

AVOIDING WIRE FEEDING PROBLEMS

Wire feeding problems can be avoided by observing the following gun handling procedures:

- Do not kink or pull cable around sharp corners.
- Keep the electrode cable as straight as possible when welding or loading electrode through cable.
- Avoid wrapping excess cable around handle or front of wire feeder especially on longer 20 and 25 ft (6.1 and 7.6 m) length guns.
- Do not allow dolly wheels or trucks to run over cables.
- Keep cable clean by following maintenance instructions.
- Use only clean, rust-free electrode. The Lincoln electrodes have proper surface lubrication.
- Replace contact tip when the arc starts to become unstable or the contact tip end is fused or deformed.

REMOVAL, INSTALLATION AND TRIMMING INSTRUCTIONS FOR MAGNUM LINERS

NOTE: The variation in cable lengths prevents the interchangeability of liners. Once a liner has been cut for a particular gun, it should not be installed in another gun, unless it can meet the liner cut off length requirement. Liners are shipped with the jacket of the liner extended the proper amount.

- Remove the gas nozzle and nozzle insulator. Loosen the set screw located in the side of the diffuser with 5/64 (2.0 mm) Allen wrench (provided with the gun or connector kit).
- Remove the gas diffuser from gun.
- Lay gun and cable out straight on a flat surface. For all K466 except K466-3 and K466-4 Connections:

Loosen set screw located in the brass cable connector at the wire feeder end of the cable using the same 5/64 (2.0 mm) Allen wrench. Pull liner out of cable. (REFER TO FIGURE 1 IN INSTALLATION FOR EACH)

<OR>

For K466-3 and K466-4 CONNECTIONS:

Remove the connector cap with the wrench provided. Pull liner out of cable. If the liner is going to be replaced with a different size liner, loosen set screw on the connector cap and remove piece of liner material.

- For installation and trimming instructions for Magnum liners see "LINER INSTALLATION" in INSTALLATION section.

GUN TUBES AND NOZZLES

- Replace worn contact tips as required.
- Remove spatter from inside of gas nozzle and from tip after each 10 minutes of arc time or as required.
- To remove gun tube from gun, loosen socket-head clamping screw in handle with 3/16" (4.8 mm) Allen wrench. Remove gas nozzle and nozzle insulator and also loosen small set screw in the diffuser using 5/64" (2.0 mm) Allen wrench.

NOTE: Small set screw in the diffuser must be loosened, otherwise liner could be damaged when attempting to remove gun tube.

Pull gun tube out from gun handle. To reinstall, insert the gun tube, push in as far as possible and retighten screws.

GUN CABLES

CABLE CLEANING

Clean cable liner after using approximately 300 pounds (136 kg) of electrode. Remove the cable from the wire feeder and lay it out straight on the floor. Remove the contact tip from the gun. Using an air hose and only partial pressure, gently blow out the cable liner from the gas diffuser end.

CAUTION

Excessive pressure at the start may cause the dirt to form a plug.

Flex the cable over its entire length and again blow out the cable. Repeat this procedure until no further dirt comes out.

CABLE REPAIR (ALL K470, K471 & K541 MODELS)

The Magnum 300 and Magnum 400 guns feature the use of repairable cable connectors. If the cable ever gets severely damaged, it may be cut shorter and repaired by the user. Repair cables as follows:

GUN TUBE END REPAIR (Requires 2 S19492-2 Terminals)

- Remove the cable liner per Removal, Installation and Trimming Instructions.
- Remove the gun tube per Gun Tubes and Nozzles Section.
- Remove three #6 screws from the gun handle, separate the two halves, and remove the cable from the handle along with the trigger assembly.
- Remove gun tube connector from cable by unscrewing connector nut from gun tube connector. If the cable inner tube is difficult to remove from the connector assembly, carefully slit it lengthwise with a knife up to the brass connector.

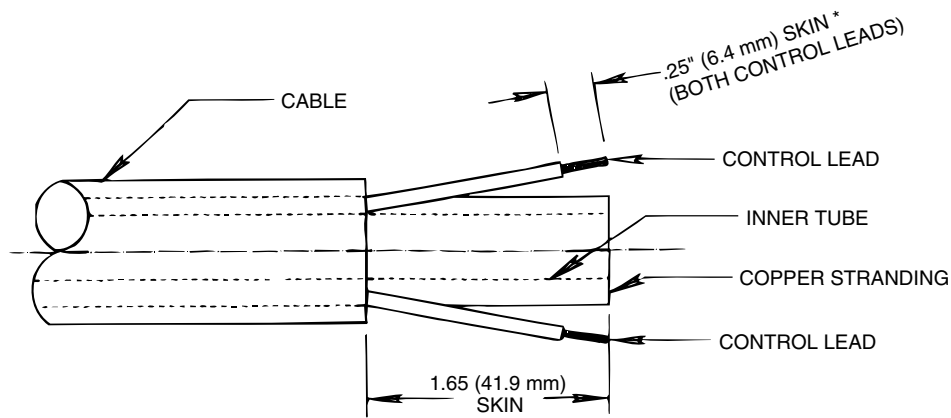

Figure 2

- e. Uncouple the strain relief by pushing its outer housing toward the middle of the cable. Move the strain relief and the cable boot toward the middle of the cable, past the damaged section.
- f. Cut off the damaged section of cable and strip off the outer jacket as shown in Figure 2. Be careful not to cut the insulation on the control wires while stripping jacket. Strip the red and white control leads 1/4 inch (6.4 mm) from the end and crimp a new S19492-2 terminal to each lead.

NOTE: The cable contains three control leads. Any two control leads can be used, provided the two colors used are the same at both ends. The extra lead is a spare that can be used if one of the other leads breaks.

- g. Check that the cable boot and both halves of the strain relief are on the cable. Slip the connector nut

over the copper strands with the thread end out. Orient gun tube connector so machined flat is on the same side of the cable as the red and white control leads. Assemble gun tube connector to cable by forcing the steel tube of the connector into the inside diameter of the cable inner tube until the copper strands are butted against the gun tube connector shoulder. Keeping the copper strands against the shoulder, pull the connector nut over the copper strands, engage the gun tube connector threads, and tighten in place. Refer to Figure 3.

NOTE: For best results, insert a .219"/.240" (5.6/6.1 mm) diameter rod through the connector and into core of cable approximately 5.00 (127 mm) when pushing the connector tube into the cable core tube. To tighten, hold the connector in place while turning the nut, then remove the rod from the core. This procedure ensures the inner core does not kink while assembling or tightening.

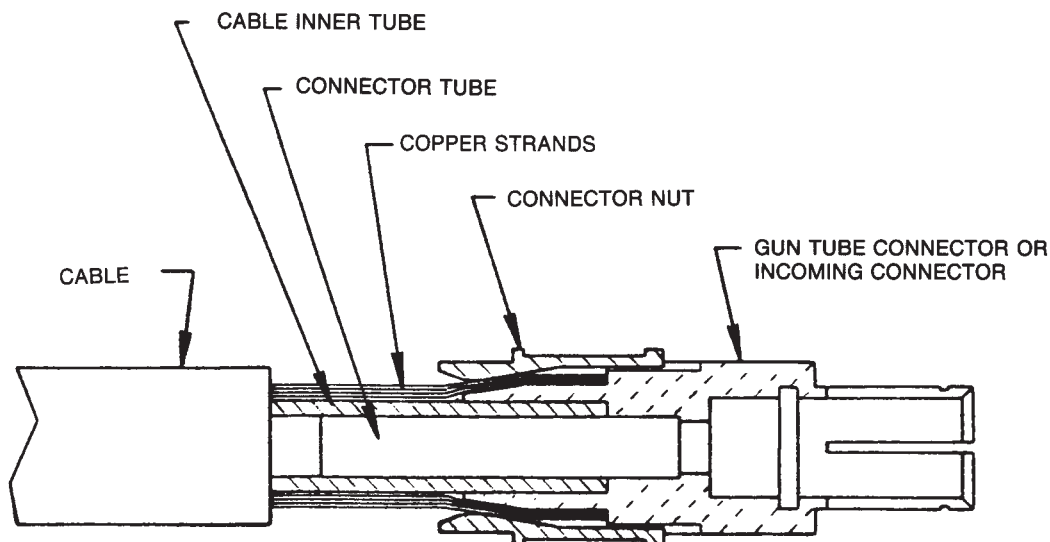

Figure 3

MAGNUM 300 & 400

- h. Pull the cut-off lead terminals off the trigger assembly and connect the replacement control lead terminals.
- j. Position the cable boot and strain relief on the cable so it fits in cable handle cavity and lock the strain relief in place by pushing the two halves together.
- k. Assemble cable in left side of gun handle. Assemble trigger into the proper handle cavity. Assemble right side of gun handle and tighten the three screws that hold the handle together. Refer to Figure 4.
- l. Install gun tube per Gun Tubes and Nozzles Section.
- m. Install and trim liner per Liner Installation Section.

WIRE FEEDER END REPAIR (Requires 2 S19492-1 Terminals)

- a. Remove the cable liner per Removal, Installation, and Trimming Instruction.
- b. Remove the feeder end connector, molded gas plug (or barbed fitting), cable handle nut, plastic

tailpiece and connector cover (see Figure 5).

NOTE: In order to remove the cable handle nut, the tail of the connector cover must be depressed and the cable handle nut rotated 1/4 turn counterclockwise as viewed from the feeder end.

- c. Remove incoming connector from cable by unscrewing connector nut from incoming connector. If the cable inner tube is difficult to remove from the connector assembly, carefully slit it lengthwise with a knife up to the brass connector.
- d. Move the cable boot and cable handle toward the middle of the cable past the damaged section.
- e. Cut off the damaged section of cable and strip off the outer jacket as shown in Figure 2. Be careful not to cut the insulation on the control wires while stripping jacket. Strip the red and white control leads 1/4 inch (6.4 mm) from the end and crimp a new S19492-1 terminal to each lead.

NOTE: The cable contains three control leads. Any two control leads can be used, provided the two colors used are the same at both ends. The extra lead is a spare that can be used if one of the other leads breaks.

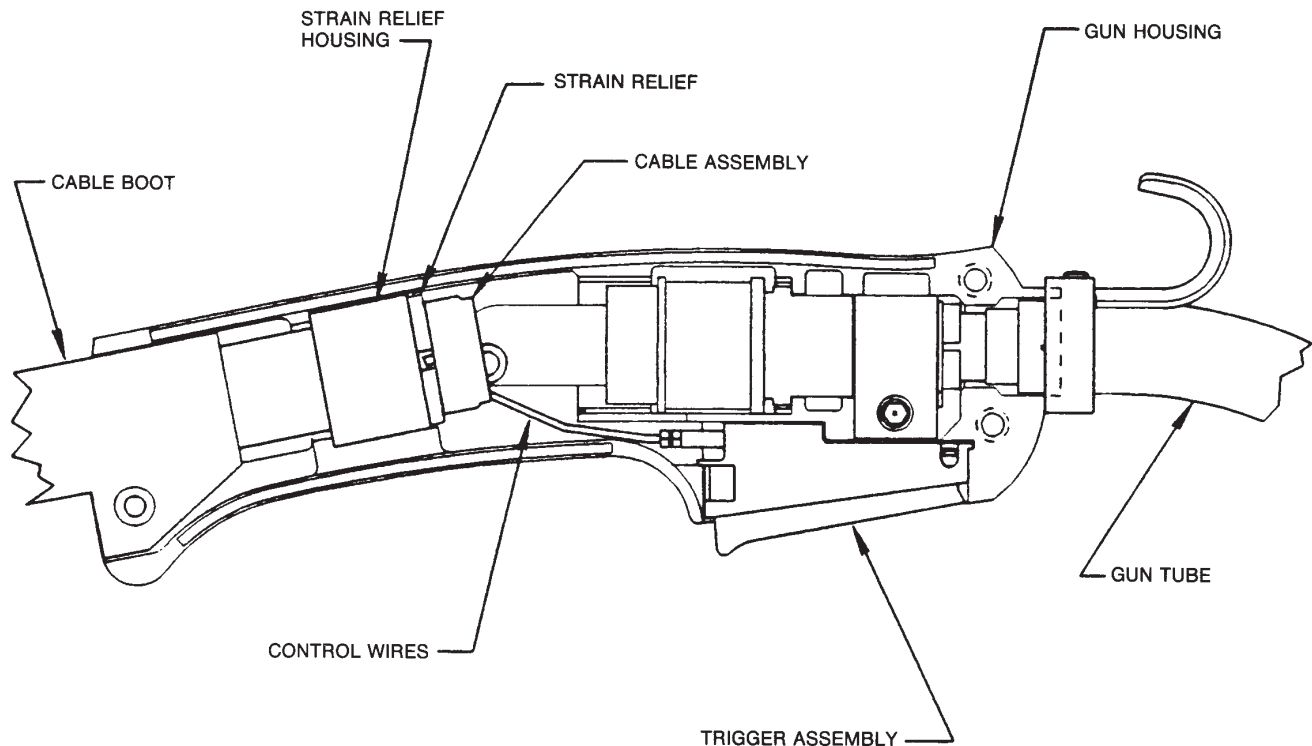

Figure 4

MAGNUM 300 & 400

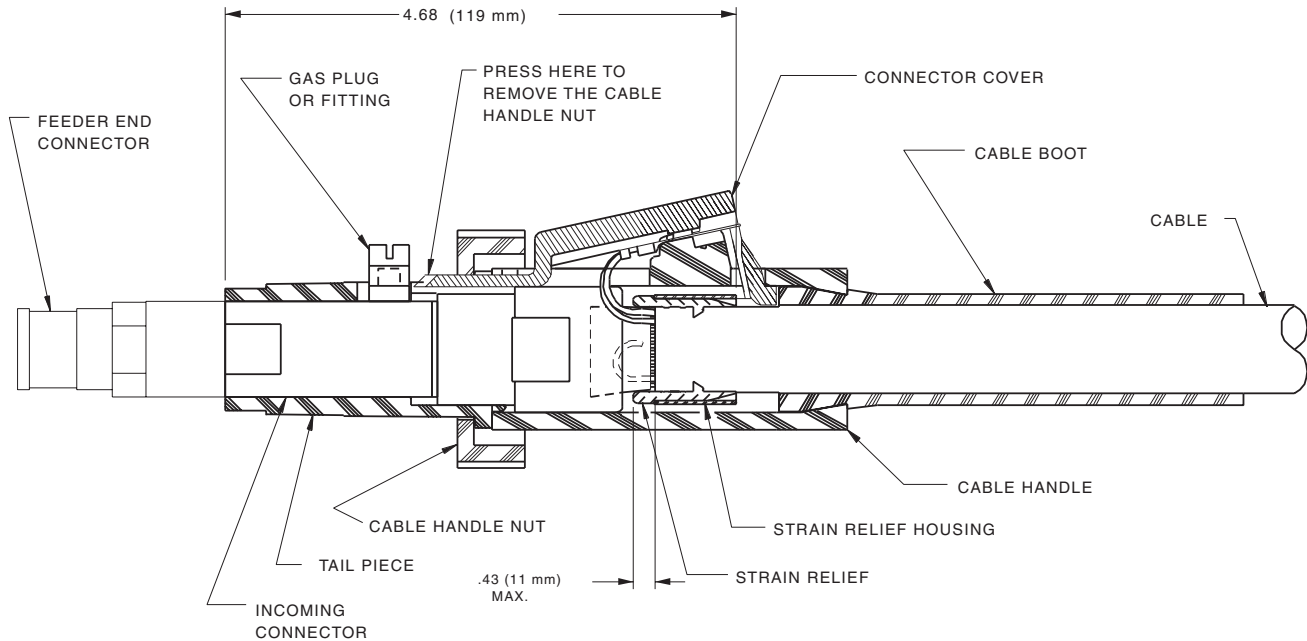

Figure 5

- f. Check that the cable boot and cable handle are on the cable. Slip the connector nut over the copper strands with the threaded end out. Assemble incoming connector to cable by forcing the steel tube of the connector into the inside diameter of the cable inner tube until the copper strands are butted against the incoming connector shoulder. Keeping the copper strands against the shoulder, pull the connector nut over the copper strands, engage the incoming connector threads, and tighten in place. Refer to Figure 3.
- g. Position cable boot and cable handle on cable and assemble replacement control wire terminals in place on the cable handle. Insert connector cover in place. Install tailpiece and fasten to cable handle with cable handle nut. Refer to Figure 5.
- h. Replace the molded gas plug (or barbed fitting) and feeder end connector.
- j. Install and trim liner per Liner Installation Section.

NOTE: For best results, insert a .219"/.240" (5.6/6.1 mm) diameter rod through the connector and into core of cable approximately 5.00" (127 mm) when pushing the connector tube into the cable core tube. To tighten, hold the connector in place while turning the nut. then remove the rod from the core. This procedure ensures the inner core does not kink while assembling or tightening.

Position the plastic strain relief such that the tapered end is 4.68 (119 mm) from the incoming connector (see Figure 5). Lock into place with steel housing. Plastic strain relief may overhang cable jacket a maximum of .43" (11 mm).

- g. Position cable boot and cable handle on cable and assemble replacement control wire terminals in place on the cable handle. Insert connector cover in place. Install tailpiece and fasten to cable handle with cable handle nut. Refer to Figure 5.

THREAD SIZES FOR MAGNUM 300 & 400 CONSUMABLES

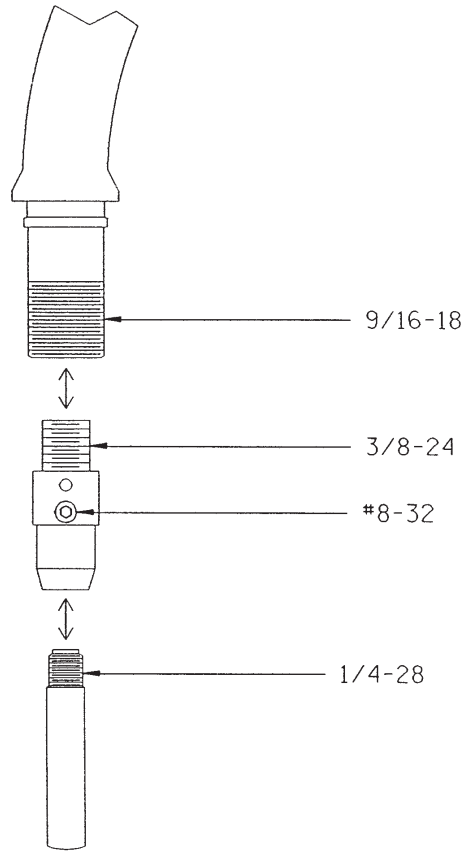

Observe all Safety Guidelines detailed throughout this manual

PROBLEMS (SYMPTOMS)	POSSIBLE CAUSE	REMEDY
PROBLEMS		
<p>Drive rolls turn, but wire will not feed or wire feeding is rough.</p>	<p>a. Gun cable kinked and/or twisted.</p> <p>b. Wire jammed in gun and cable.</p> <p>c. Incorrect drive rolls and guide tubes.</p> <p>d. Gun cable liner dirty.</p> <p>e. Worn drive rolls.</p> <p>f. Electrode rusty and/or dirty.</p> <p>g. Worn or improper size cable liner.</p> <p>h. Partially flashed, melted or improper size contact tip.</p>	<p>a. Keep as straight as possible. Inspect cable and replace if necessary.</p> <p>b. Remove wire from gun and cable – feed in new wire. Note any obstruction. Replace liner if necessary.</p> <p>c. Be sure the wire diameter being used is stamped on drive rolls and guide tubes. Replace if necessary.</p> <p>d. Clean liner or replace.</p> <p>e. Replace or reverse split drive roll type.</p> <p>f. Replace the electrode if it is rusty.</p> <p>g. Replace cable liner.</p> <p>h. Replace the contact tip.</p>
<p>Variable or “hunting” arc.</p>	<p>a. Contact tip worn or incorrect size.</p> <p>b. Worn or undersize work cables or poor ground connections.</p> <p>c. Loose electrode connections.</p>	<p>a. Replace contact tip.</p> <p>b. Inspect – repair or replace as necessary.</p> <p>c. Be sure the following connections are tight: electrode cable to wire feeder and power source, work cable to power source and work, gun cable to wire feeder contact block, gun nozzle to body and contact tip to nozzle.</p>

 **CAUTION**

If for any reason you do not understand the test procedures or are unable to perform the tests/repairs safely, contact your **Local Lincoln Authorized Field Service Facility** for technical troubleshooting assistance before you proceed.

MAGNUM 300 & 400



Observe all Safety Guidelines detailed throughout this manual

PROBLEMS (SYMPTOMS)	POSSIBLE CAUSE	REMEDY
PROBLEMS		
<p>Poor arc striking with sticking or "blast-offs", weld porosity, narrow and ropy looking bead, or electrode stubbing into plate while welding.</p>	<p>a. Improper procedures or techniques. b. Improper gas shielding.</p>	<p>a. See "Gas Metal Arc Welding Guide" (GS100). b. Clean gas cone. Make certain that gas diffuser is not restricted. Make certain that gas cylinder is not empty or turned off. Make certain gas solenoid valve is operating and gas flow rate is proper. Remove gun liner and check rubber seal for any sign of deterioration or damage. Be sure set screw in brass connector is in place and tightened against the liner bushing.</p>
<p>Tip seizes in diffuser.</p>	<p>a. Tip overheating due to prolonged or excessive high current and/or duty cycle welding.</p>	<p>a. Do not exceed current and duty cycle rating of gun. A light application of high temperature antiseize lubricant (such as Lincoln E2067 Graphite Grease) may be applied to tip threads.</p>

 **CAUTION**

If for any reason you do not understand the test procedures or are unable to perform the tests/repairs safely, contact your **Local Lincoln Authorized Field Service Facility** for technical troubleshooting assistance before you proceed.

MAGNUM 300 & 400



NOTES

MAGNUM 300 & 400



NOTES

MAGNUM 300 & 400



			
WARNING	<ul style="list-style-type: none"> ● Do not touch electrically live parts or electrode with skin or wet clothing. ● Insulate yourself from work and ground. 	<ul style="list-style-type: none"> ● Keep flammable materials away. 	<ul style="list-style-type: none"> ● Wear eye, ear and body protection.
Spanish AVISO DE PRECAUCION	<ul style="list-style-type: none"> ● No toque las partes o los electrodos bajo carga con la piel o ropa mojada. ● Aislese del trabajo y de la tierra. 	<ul style="list-style-type: none"> ● Mantenga el material combustible fuera del área de trabajo. 	<ul style="list-style-type: none"> ● Protéjase los ojos, los oídos y el cuerpo.
French ATTENTION	<ul style="list-style-type: none"> ● Ne laissez ni la peau ni des vêtements mouillés entrer en contact avec des pièces sous tension. ● Isolez-vous du travail et de la terre. 	<ul style="list-style-type: none"> ● Gardez à l'écart de tout matériel inflammable. 	<ul style="list-style-type: none"> ● Protégez vos yeux, vos oreilles et votre corps.
German WARNUNG	<ul style="list-style-type: none"> ● Berühren Sie keine stromführenden Teile oder Elektroden mit Ihrem Körper oder feuchter Kleidung! ● Isolieren Sie sich von den Elektroden und dem Erdboden! 	<ul style="list-style-type: none"> ● Entfernen Sie brennbares Material! 	<ul style="list-style-type: none"> ● Tragen Sie Augen-, Ohren- und Körperschutz!
Portuguese ATENÇÃO	<ul style="list-style-type: none"> ● Não toque partes elétricas e electrodos com a pele ou roupa molhada. ● Isole-se da peça e terra. 	<ul style="list-style-type: none"> ● Mantenha inflamáveis bem guardados. 	<ul style="list-style-type: none"> ● Use proteção para a vista, ouvido e corpo.
Japanese 注意事項	<ul style="list-style-type: none"> ● 通電中の電気部品、又は溶材にヒフやぬれた布で触れないこと。 ● 施工物やアースから身体が絶縁されている様にして下さい。 	<ul style="list-style-type: none"> ● 燃えやすいものの側での溶接作業は絶対してはなりません。 	<ul style="list-style-type: none"> ● 目、耳及び身体に保護具をして下さい。
Chinese 警告	<ul style="list-style-type: none"> ● 皮肤或湿衣物切勿接触带电部件及焊条。 ● 使你自己与地面和工件绝缘。 	<ul style="list-style-type: none"> ● 把一切易燃物品移离工作场所。 	<ul style="list-style-type: none"> ● 佩戴眼、耳及身体劳动保护用具。
Korean 위험	<ul style="list-style-type: none"> ● 전도체나 용접봉을 젖은 항갑 또는 피부로 절대 접촉치 마십시오. ● 모재와 접지를 접촉치 마십시오. 	<ul style="list-style-type: none"> ● 인화성 물질을 접근 시키지 마십시오. 	<ul style="list-style-type: none"> ● 눈, 귀와 몸에 보호장구를 착용하십시오.
Arabic تحذير	<ul style="list-style-type: none"> ● لا تلمس الاجزاء التي يسري فيها التيار الكهربائي أو الإلكترود بجلد الجسم أو بالملابس المبللة بالماء. ● ضع عازلا على جسمك خلال العمل. 	<ul style="list-style-type: none"> ● ضع المواد القابلة للاشتعال في مكان بعيد. 	<ul style="list-style-type: none"> ● ضع أدوات وملابس واقية على عينيك وأذنيك وجسمك.

READ AND UNDERSTAND THE MANUFACTURER'S INSTRUCTION FOR THIS EQUIPMENT AND THE CONSUMABLES TO BE USED AND FOLLOW YOUR EMPLOYER'S SAFETY PRACTICES.

SE RECOMIENDA LEER Y ENTENDER LAS INSTRUCCIONES DEL FABRICANTE PARA EL USO DE ESTE EQUIPO Y LOS CONSUMIBLES QUE VA A UTILIZAR, SIGA LAS MEDIDAS DE SEGURIDAD DE SU SUPERVISOR.

LISEZ ET COMPRENEZ LES INSTRUCTIONS DU FABRICANT EN CE QUI REGARDE CET EQUIPMENT ET LES PRODUITS A ETRE EMPLOYES ET SUIVEZ LES PROCEDURES DE SECURITE DE VOTRE EMPLOYEUR.

LESEN SIE UND BEFOLGEN SIE DIE BETRIEBSANLEITUNG DER ANLAGE UND DEN ELEKTRODENEINSATZ DES HERSTELLERS. DIE UNFALLVERHÜTUNGSVORSCHRIFTEN DES ARBEITGEBERS SIND EBENFALLS ZU BEACHTEN.

			
<ul style="list-style-type: none"> ● Keep your head out of fumes. ● Use ventilation or exhaust to remove fumes from breathing zone. 	<ul style="list-style-type: none"> ● Turn power off before servicing. 	<ul style="list-style-type: none"> ● Do not operate with panel open or guards off. 	WARNING
<ul style="list-style-type: none"> ● Los humos fuera de la zona de respiración. ● Mantenga la cabeza fuera de los humos. Utilice ventilación o aspiración para gases. 	<ul style="list-style-type: none"> ● Desconectar el cable de alimentación de poder de la máquina antes de iniciar cualquier servicio. 	<ul style="list-style-type: none"> ● No operar con panel abierto o guardas quitadas. 	Spanish AVISO DE PRECAUCION
<ul style="list-style-type: none"> ● Gardez la tête à l'écart des fumées. ● Utilisez un ventilateur ou un aspirateur pour ôter les fumées des zones de travail. 	<ul style="list-style-type: none"> ● Débranchez le courant avant l'entretien. 	<ul style="list-style-type: none"> ● N'opérez pas avec les panneaux ouverts ou avec les dispositifs de protection enlevés. 	French ATTENTION
<ul style="list-style-type: none"> ● Vermeiden Sie das Einatmen von Schweißrauch! ● Sorgen Sie für gute Be- und Entlüftung des Arbeitsplatzes! 	<ul style="list-style-type: none"> ● Strom vor Wartungsarbeiten abschalten! (Netzstrom völlig öffnen; Maschine anhalten!) 	<ul style="list-style-type: none"> ● Anlage nie ohne Schutzgehäuse oder Innenschutzverkleidung in Betrieb setzen! 	German WARNUNG
<ul style="list-style-type: none"> ● Mantenha seu rosto da fumaça. ● Use ventilação e exaustão para remover fumo da zona respiratória. 	<ul style="list-style-type: none"> ● Não opere com as tampas removidas. ● Desligue a corrente antes de fazer serviço. ● Não toque as partes elétricas nuas. 	<ul style="list-style-type: none"> ● Mantenha-se afastado das partes moventes. ● Não opere com os painéis abertos ou guardas removidas. 	Portuguese ATENÇÃO
<ul style="list-style-type: none"> ● ヒュームから頭を離すようにして下さい。 ● 換気や排煙に十分留意して下さい。 	<ul style="list-style-type: none"> ● メンテナンス・サービスに取りかかる際には、まず電源スイッチを必ず切ってください。 	<ul style="list-style-type: none"> ● パネルやカバーを取り外したままで機械操作をしないで下さい。 	Japanese 注意事項
<ul style="list-style-type: none"> ● 頭部遠離煙霧。 ● 在呼吸區使用通風或排風器除煙。 	<ul style="list-style-type: none"> ● 維修前切斷電源。 	<ul style="list-style-type: none"> ● 儀表板打開或沒有安全罩時不準作業。 	Chinese 警告
<ul style="list-style-type: none"> ● 얼굴로부터 용접가스를 멀리하십시오. ● 호흡지역으로부터 용접가스를 제거하기 위해 가스제거기나 통풍기를 사용하십시오. 	<ul style="list-style-type: none"> ● 보수전에 전원을 차단하십시오. 	<ul style="list-style-type: none"> ● 관널이 열린 상태로 작동치 마십시오. 	Korean 위험
<ul style="list-style-type: none"> ● ابعء رأسك بعيداً عن الدخان. ● استعمل التهوية أو جهاز ضغط الدخان للخارج لكي تبعد الدخان عن المنطقة التي تتنفس فيها. 	<ul style="list-style-type: none"> ● أقطع التيار الكهربائي قبل القيام بأية صيانة. 	<ul style="list-style-type: none"> ● لا تشغيل هذا الجهاز اذا كانت الاغطية الحديدية الواقية ليست عليه. 	Arabic تحذير

LEIA E COMPREENDA AS INSTRUÇÕES DO FABRICANTE PARA ESTE EQUIPAMENTO E AS PARTES DE USO, E SIGA AS PRÁTICAS DE SEGURANÇA DO EMPREGADOR.

使う機械や溶材のメーカーの指示書をよく読み、まず理解して下さい。そして貴社の安全規定に従って下さい。

請詳細閱讀並理解製造廠提供的說明以及應該使用的銀焊材料，並請遵守貴方的有關勞動保護規定。

이 제품에 동봉된 작업지침서를 숙지하시고 귀사의 작업자 안전수칙을 준수하시기 바랍니다.

اقرأ بتمعن وأفهم تعليمات المصنع المنتج لهذه المعدات والمواد قبل استعمالها واتبع تعليمات الوقاية لصاحب العمل.



• World's Leader in Welding and Cutting Products •

• Sales and Service through Subsidiaries and Distributors Worldwide •

Cleveland, Ohio 44117-1199 U.S.A. TEL: 216.481.8100 FAX: 216.486.1751 WEB SITE: www.lincolnelectric.com