

The BUG-GY... Automatic Fillet Welder.

Increase Welding Production.
Improve Weld Quality.



Welding & Cutting Automation
Since 1948.



BUG-GY Fillet Welder AFW-3000

The BUG-GY Fillet Welder is designed for making continuous or intermittent stitch welds on fillet, lap or butt joints. It is a lightweight portable carriage that uses powerful magnets and guide wheels to clamp and track on the work piece. The BUG-GY is self-guiding and requires little operator input once it is set up. It can be programmed for stitch welding by distance and features automatic weld back for crater fill. Between stitch welds the BUG-GY accelerates to a top speed of 120 ipm (300 mm/min). Dynamic breaking and closed loop feed back allow the BUG-GY to make crisp starts and stops and to travel at precise speeds. Limit switches provide automatic shutoff at the end of the joint.



The BUG-GY can follow any outside edge.



The BUG-GY can weld lap joints with a minimum height of 3/8" (9.53 mm).

Controls:

- A. Digital travel speed display.
- B. Weld length programming button.
- C. Skip length programming button.
- D. Reverse crater fill programming button.
- E. Programming button.
- F. Travel start button - left.
- G. Travel stop button.
- H. Travel start button - right.
- I. Travel speed knob.
- J. Mode select switch, continuous or stitch.
- K. Arc enable On/Off switch #1.
- L. Arc enable On/Off switch #2.
- M. Power switch.
- N. Weld contactor.

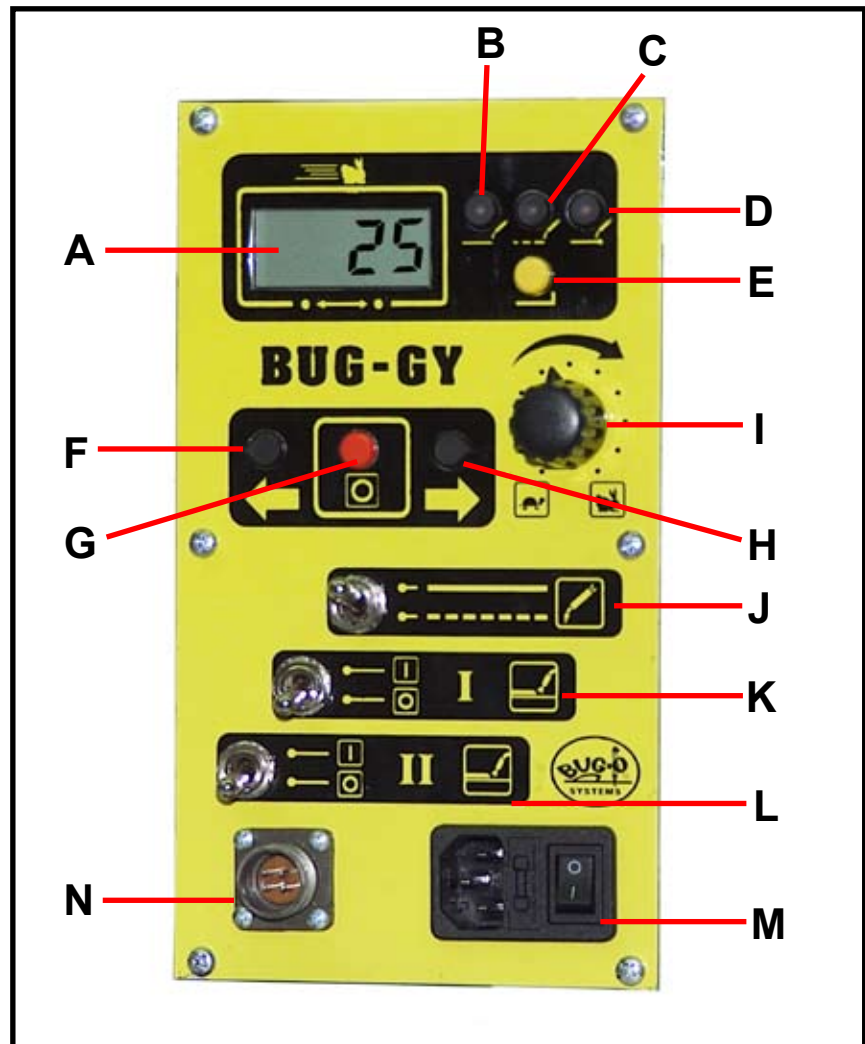



BUG-GY Fillet Welder AFW-3000

Optional Equipment:



AFW-2275 Dual Gun Mounting Group.

This optional support group provides dual welding on stiffeners up to 18" (460 mm) high.



Optional Sub Arc Gun.

15' long, 550 amp, 60% duty cycle sub arc gun works in conjunction with the BUG-GY to perform automatic submerged arc welds. Available with either Lincoln or Miller connectors. Designed for running 1/16" - 5/64" or 3/32" wire.



Lincoln® Style Connector.

AFW-2285-5/64
AFW-2285-3/32

Miller® Style Connector.

AFW-2290-5/64
AFW-2290-3/32

Replacement Contact Tips:

AFW-2291 1/16" wire size
AFW-2292 5/64" wire size
AFW-2293 3/32" wire size



BUG-GY Fillet Welder AFW-3000

Features:

1. Lightweight.
2. Easy to carry.
3. Permanent magnet for powerful traction.
4. Built-in programmable stitching by distance.
5. Dual mode selector switch for stitch or continuous welding.
6. 4 to 60 ipm (10 - 152 cm/m) welding speed range can be preset.
7. Rapid traverse between welds at 120 ipm (300 cm/m).
8. Built-in dual weld contactor connection.
9. Adjustable end on weld back-up.
10. Dynamic braking for crisp starts and stops.
11. Digital LCD speed indicator.
12. Closed loop speed & position control.
13. Limit switches provide automatic weld stop.
14. Spatter guard on work-side wheels.
15. Versatile gun support with most MIG guns.
16. Precision micro-adjustable "Y" & "Z" slides for gun positioning.
17. Available in three operating voltages: 42, 110 & 220 VAC.

Specifications:

Power

Requirements:

AFW-3000	120 VAC/50-60/1
AFW-3002	240 VAC/50-60/1
AFW-3004	42VAC/50-60/1

Travel Modes:

1. Continuous
2. Stitch: weld
crater fill
skip

Travel Speeds:

Welding	4-60 ipm (10-152 cm/m)
Skip	120 ipm (300 cm/m)

Net Weight: 27 lbs. (12.5 kg)

Shipping Weight: 34 lbs. (15.5 kg)

Dimensions:

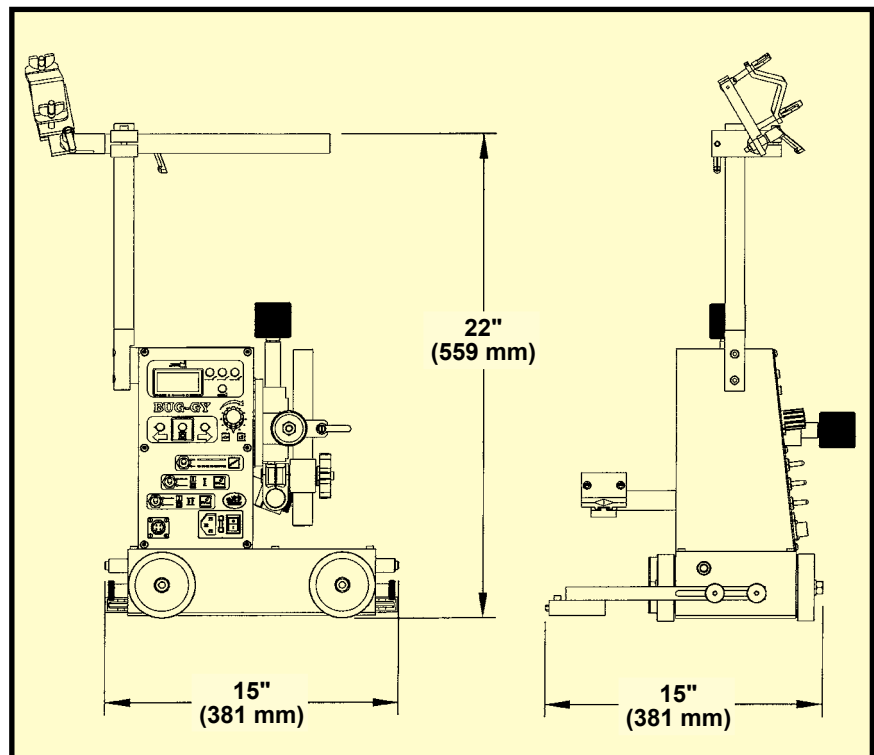

For more information on the BUG-GY call 800-245-3186 or 412-331-1776.