

LG PP 400 W

| | Part No. |
|-------------------------------------|-------------|
| LG PP 400 W - 8.0 m - w/o encoders | K10413-PPW |
| LG PP 400 W - 8.0 m - with encoders | K10413-PPWR |

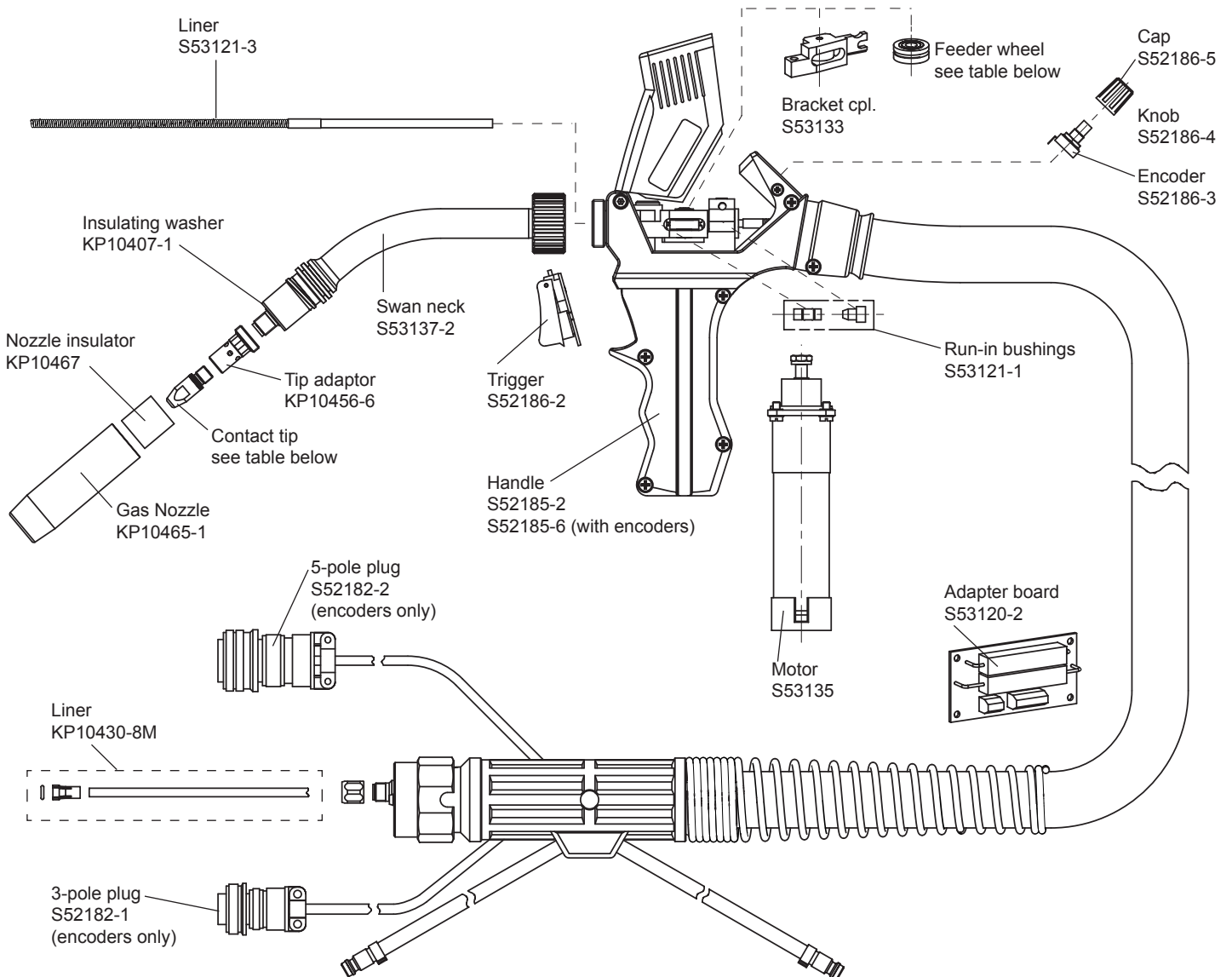

| | Ø | 0.8 mm | 1.0 mm | 1.2 mm | 1.4 mm | 1.6 mm |
|----------------------------|---|-------------|---------------|----------------------|-------------|-------------|
| Al (ECu) M8 x 30 mm | | KP10445-08A | KP10445-10A | KP10445-12A | KP10445-14A | KP10445-16A |
| Al (Polygon) M8 x 30 mm | | | KP10445-10PLG | KP10445-12PLG | | |
| Feeder wheel | | S53131-1 | S53131-2 | S53131-3 | S53131-4 | S53131-5 |